

⚠ Please note that VHB adhesion takes 24 hours. **NOTES BEFORE INSTALLING:** Clean back of device and top of Puck with alcohol wipe. Do not over-tighten screws. Over-tightening screws may damage devices and Freedom products.

PARTS LIST

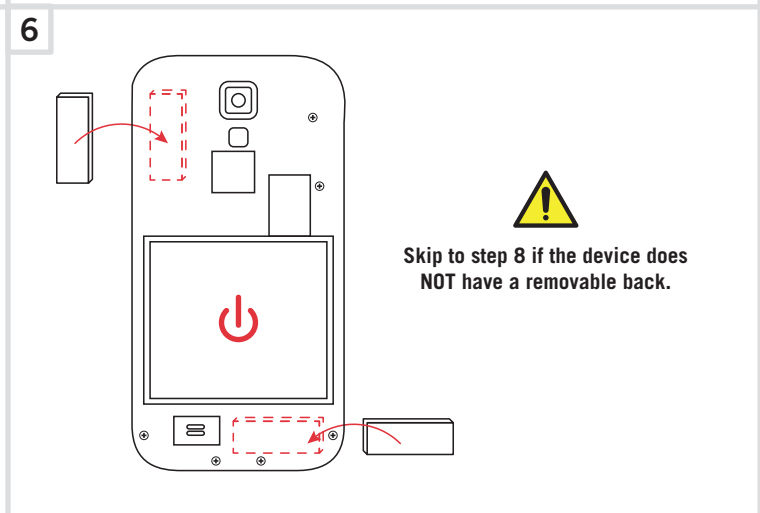

7

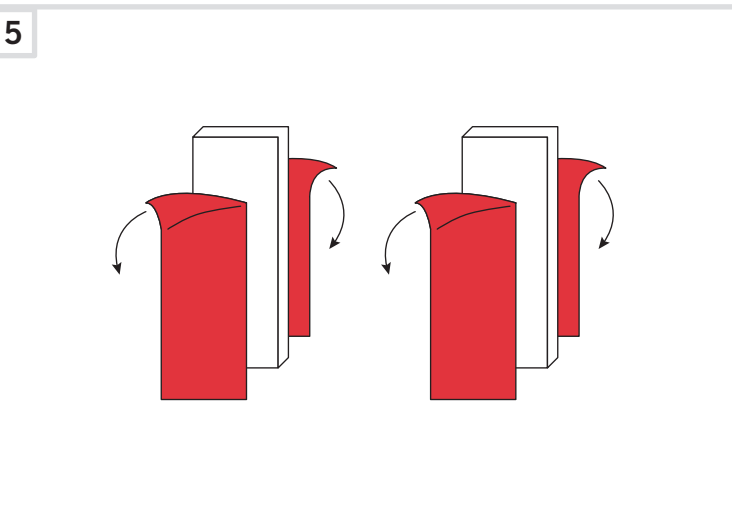
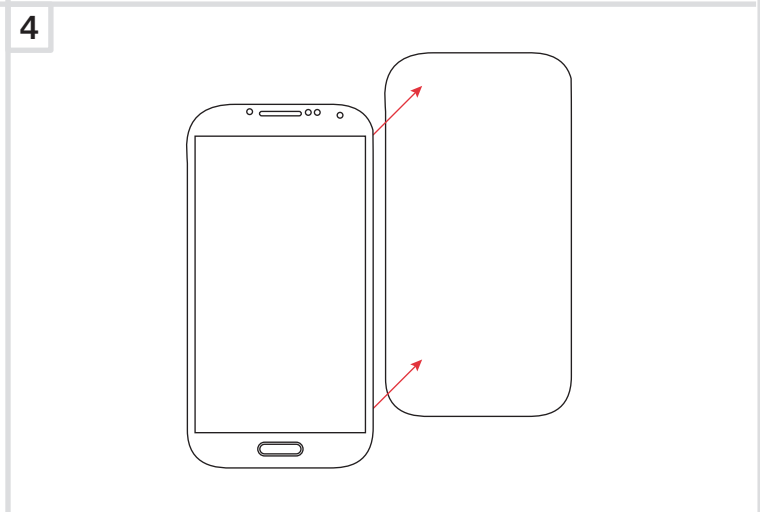
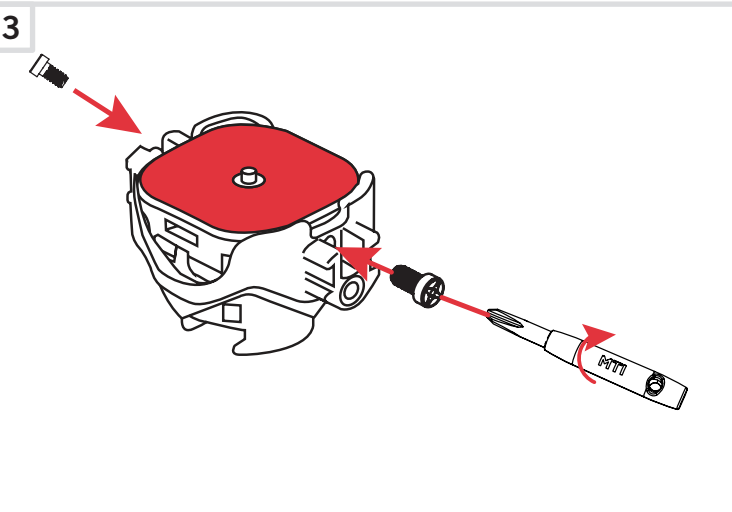
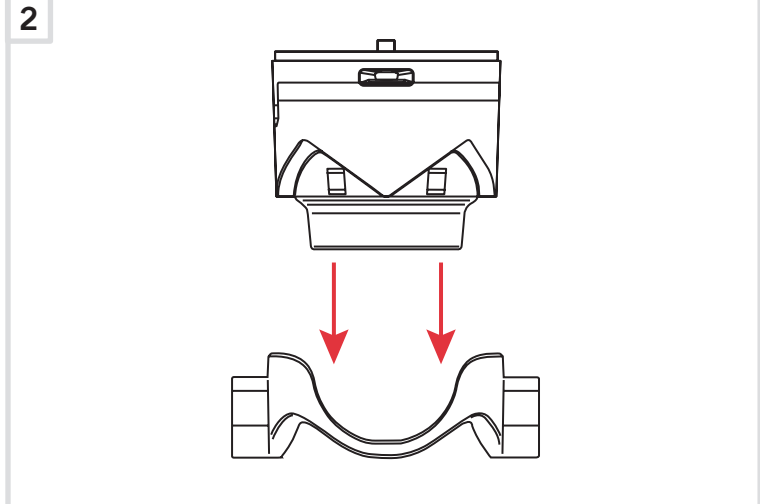
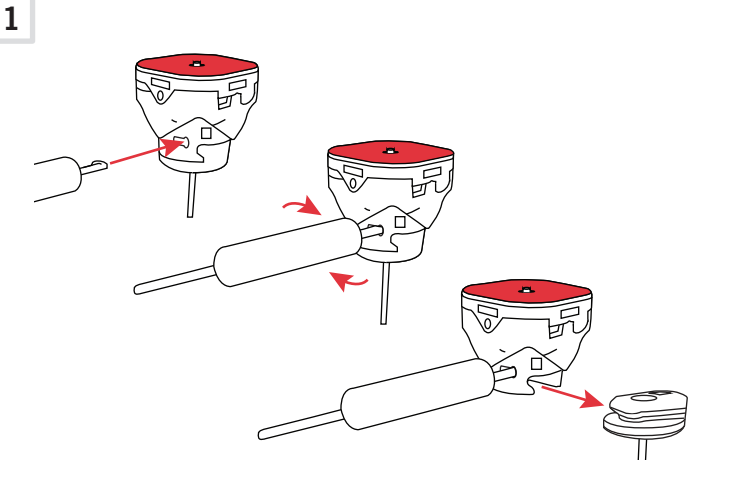
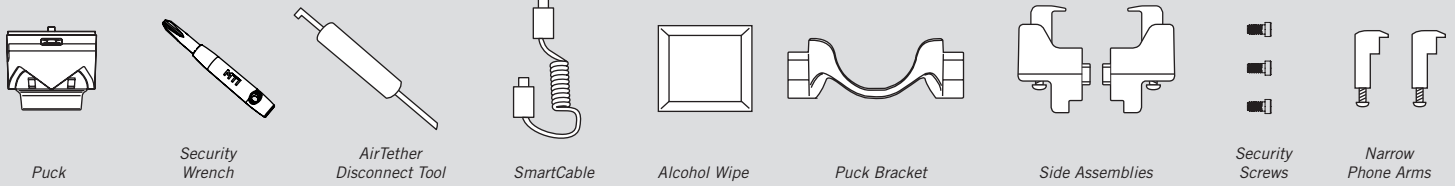
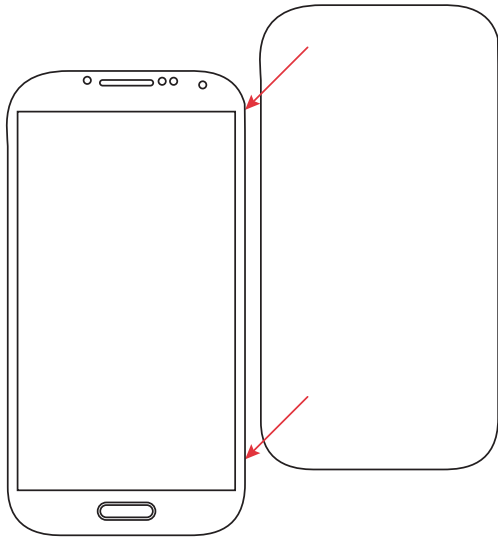

8

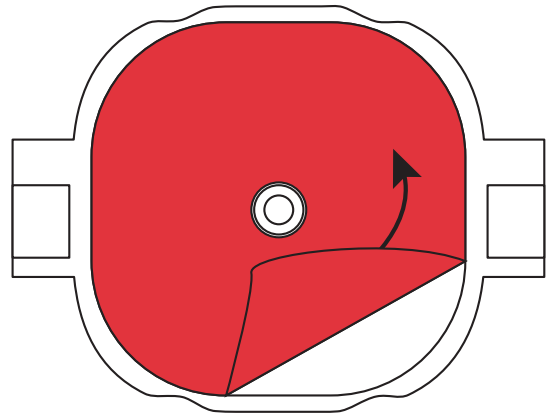

9

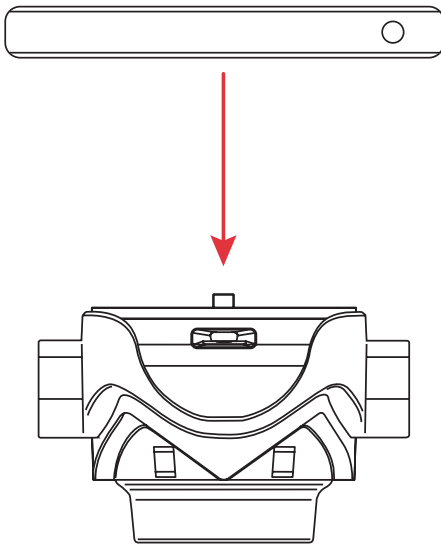

10

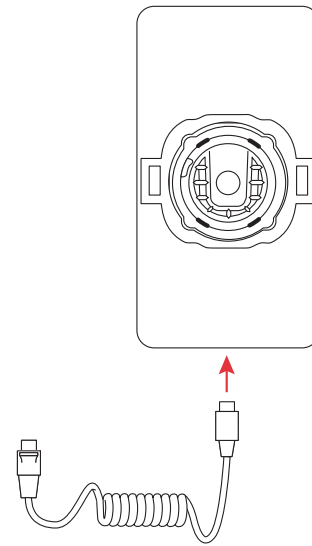

11

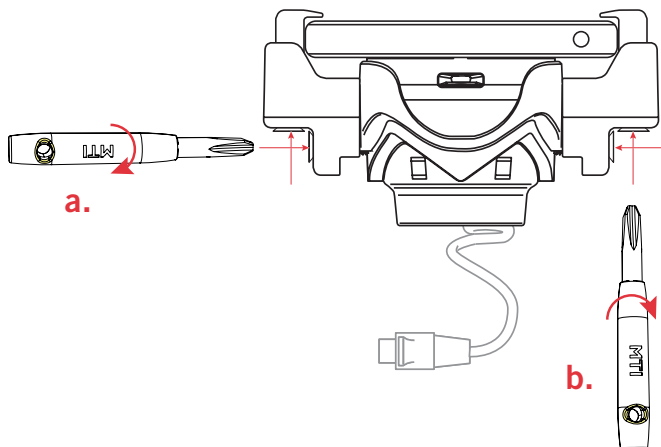

12

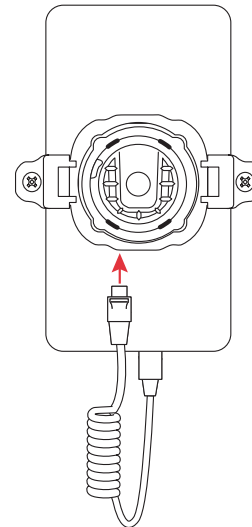

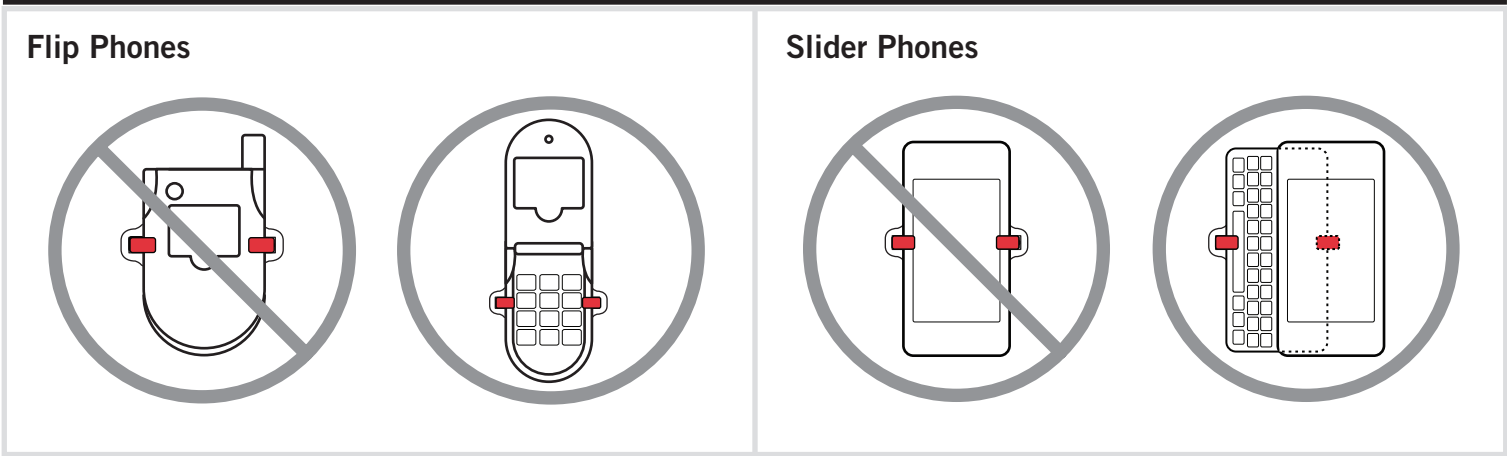

SHUKO ARM REPLACEMENT

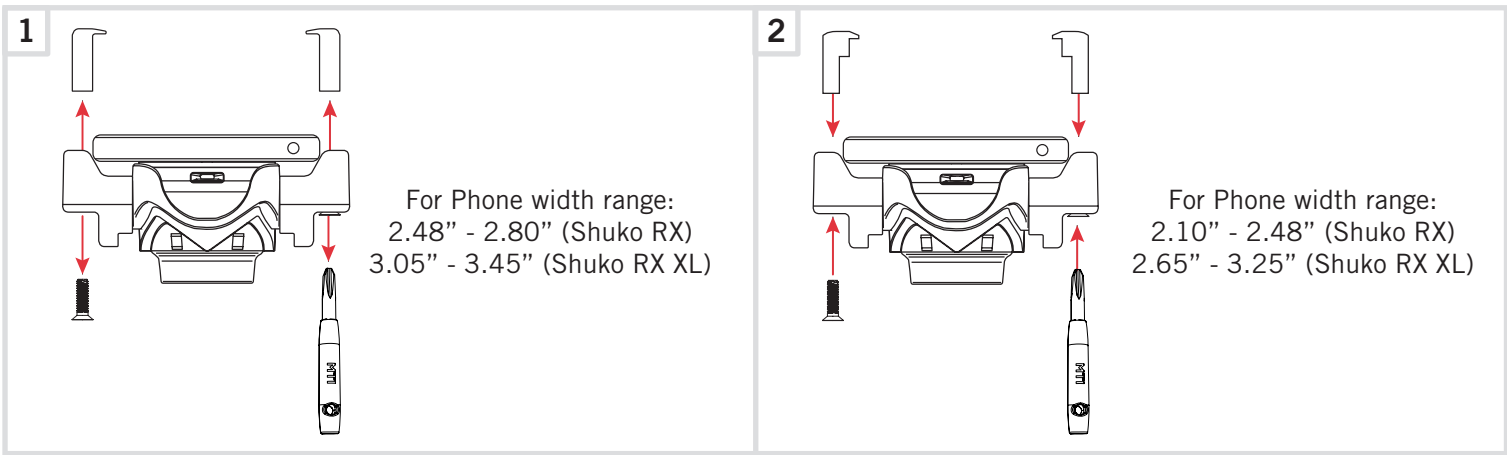

REMOVAL

