

1

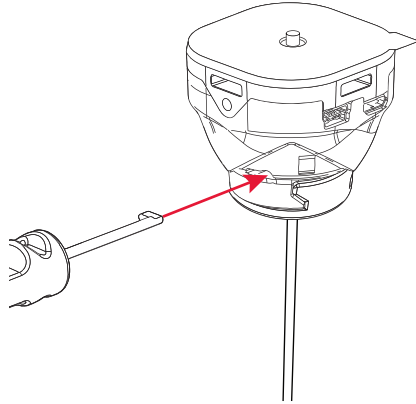

2

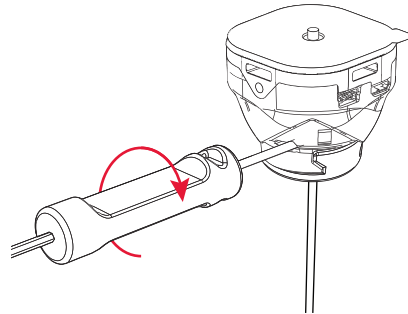

3

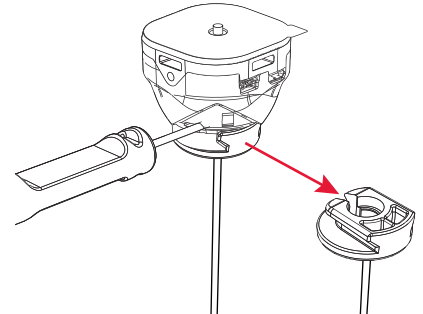

# ARMING THE SYSTEM

1

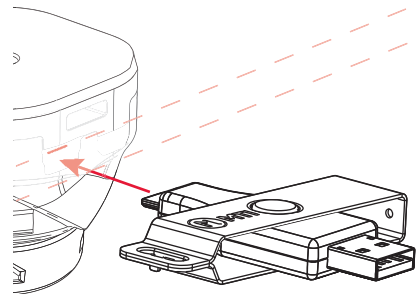

2

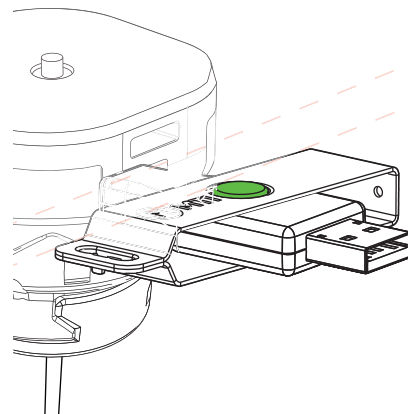

3

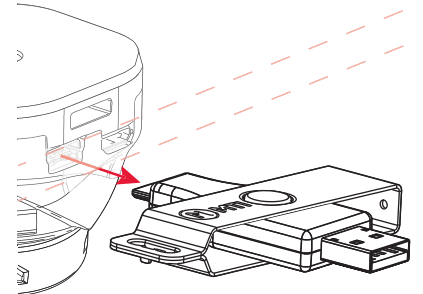

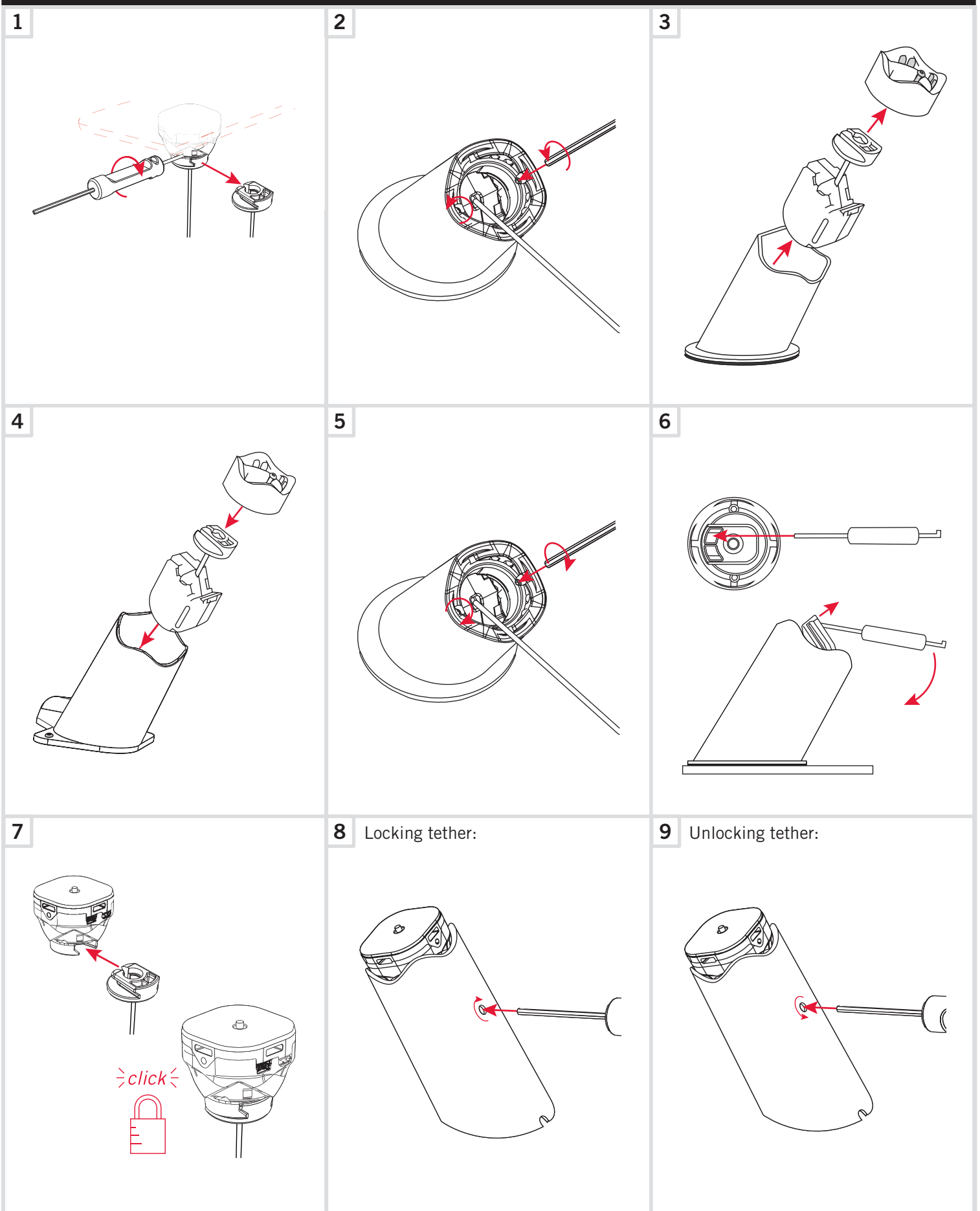

1

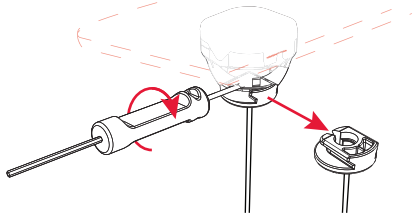

2

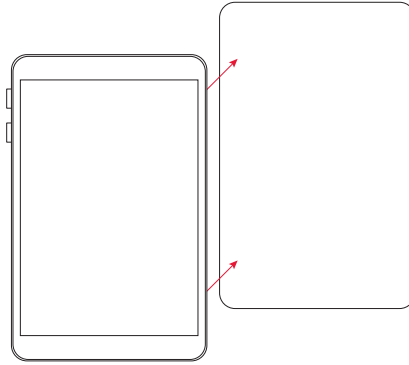

3

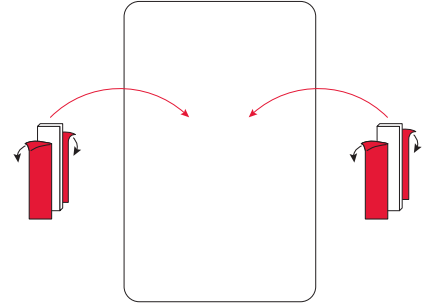

4

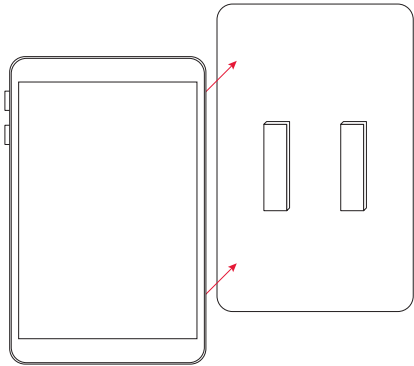

5

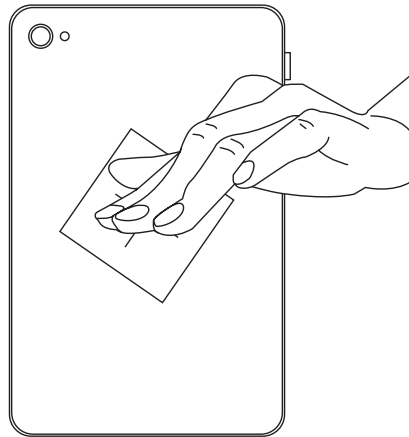

6

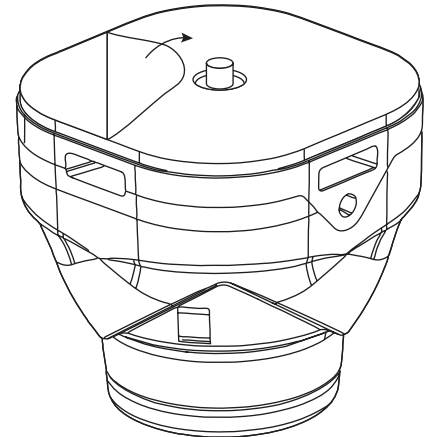

7

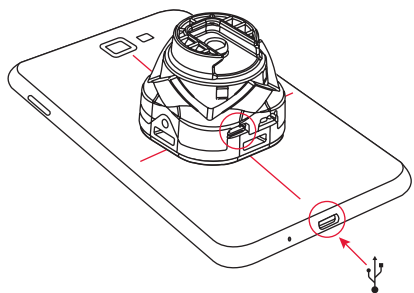

8

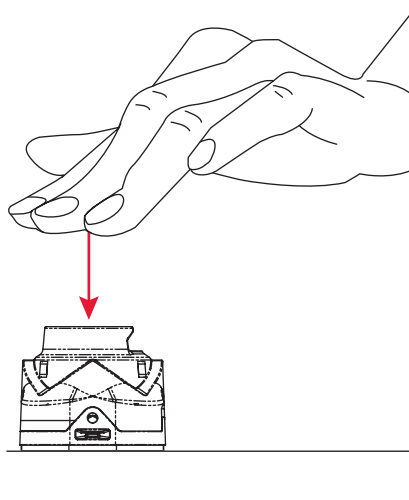

9

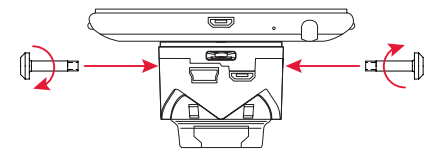

10

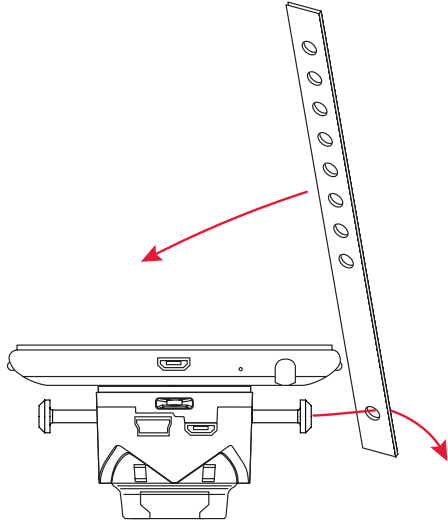

11

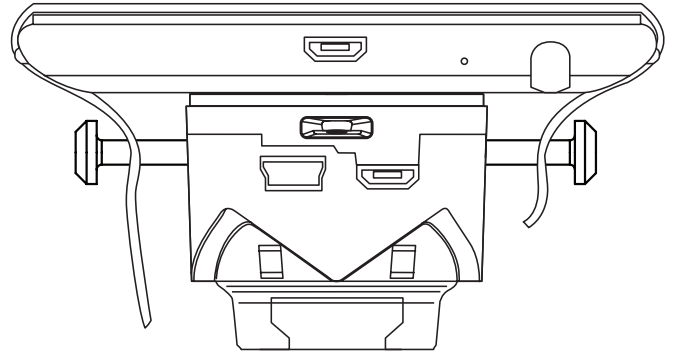

Please note that VHB adhesion takes 24 hours.

12

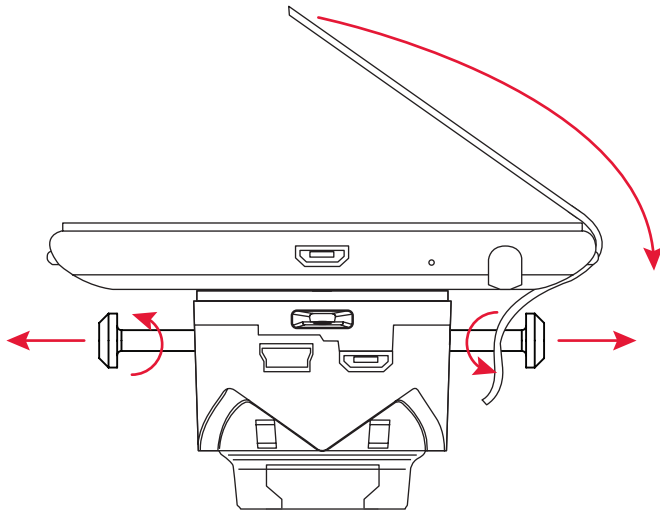

13

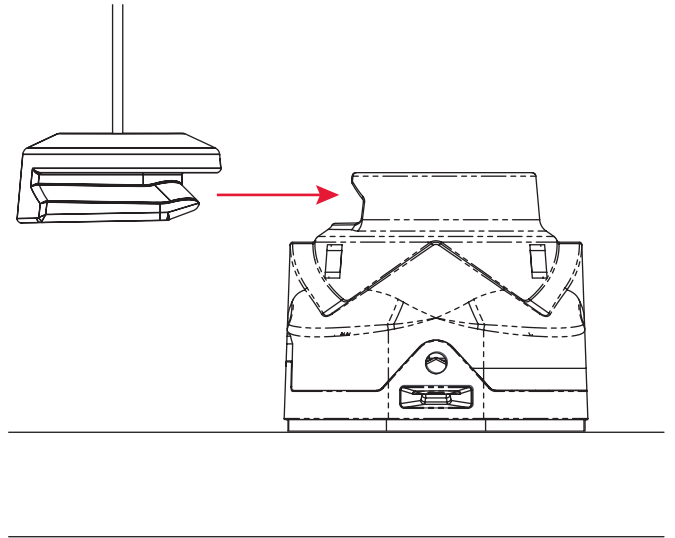

14

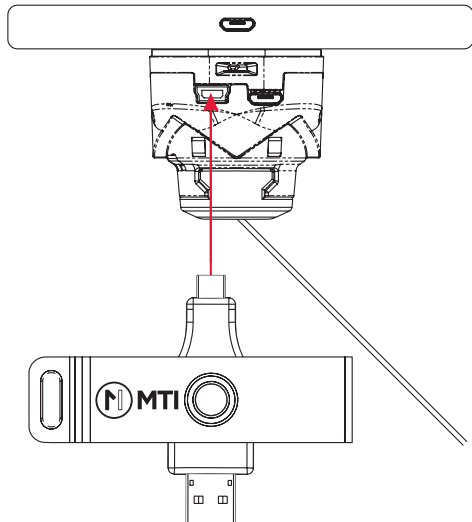

15

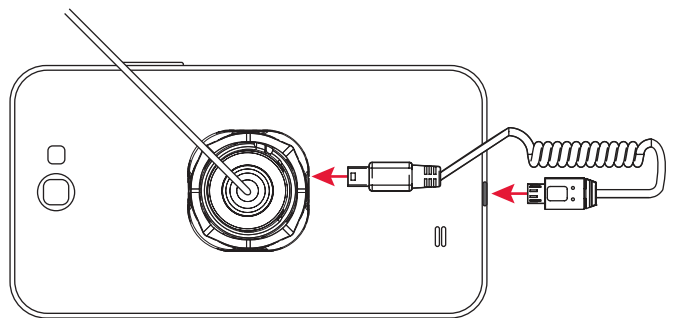

# PUCK REMOVAL

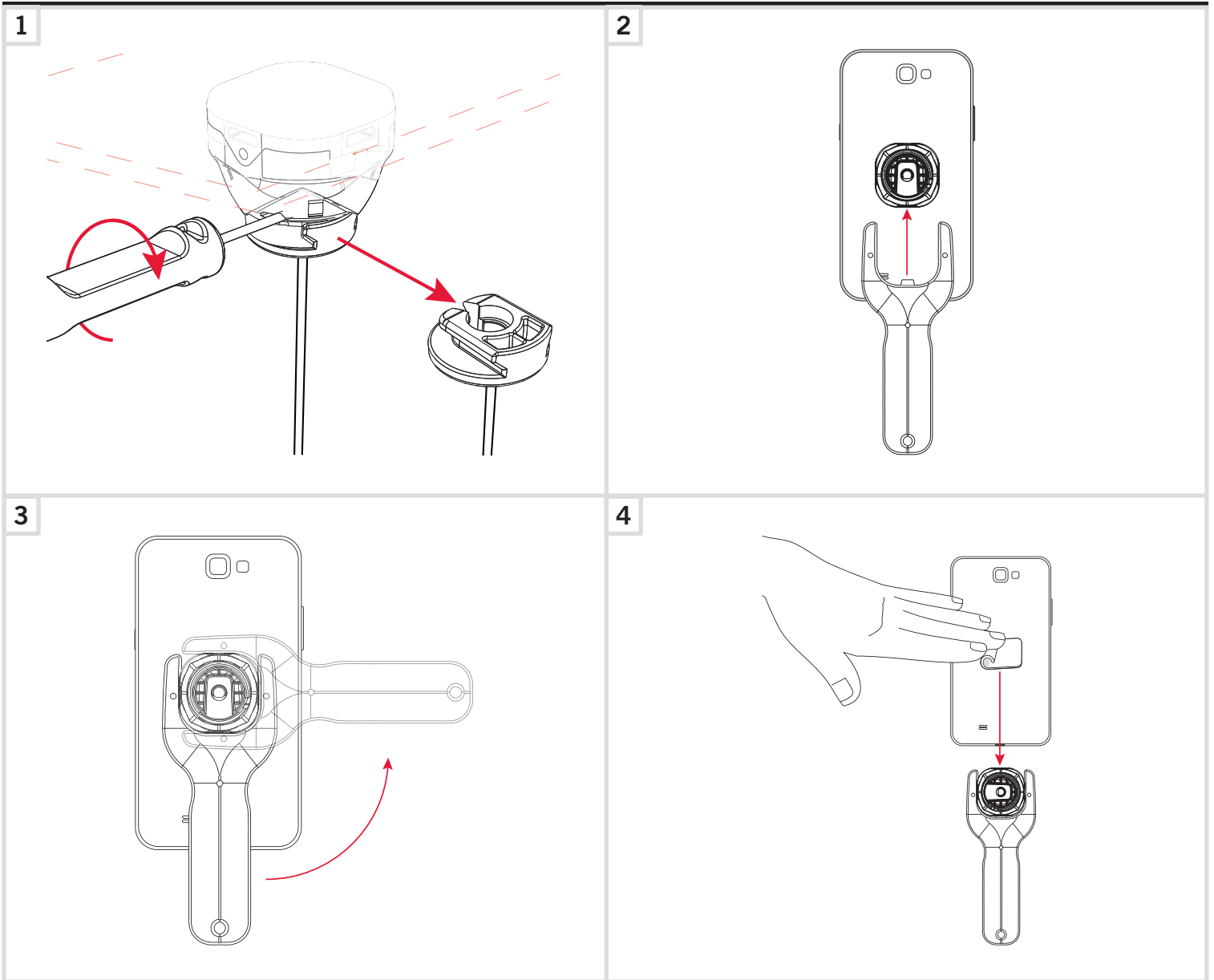

# RISER REMOVAL

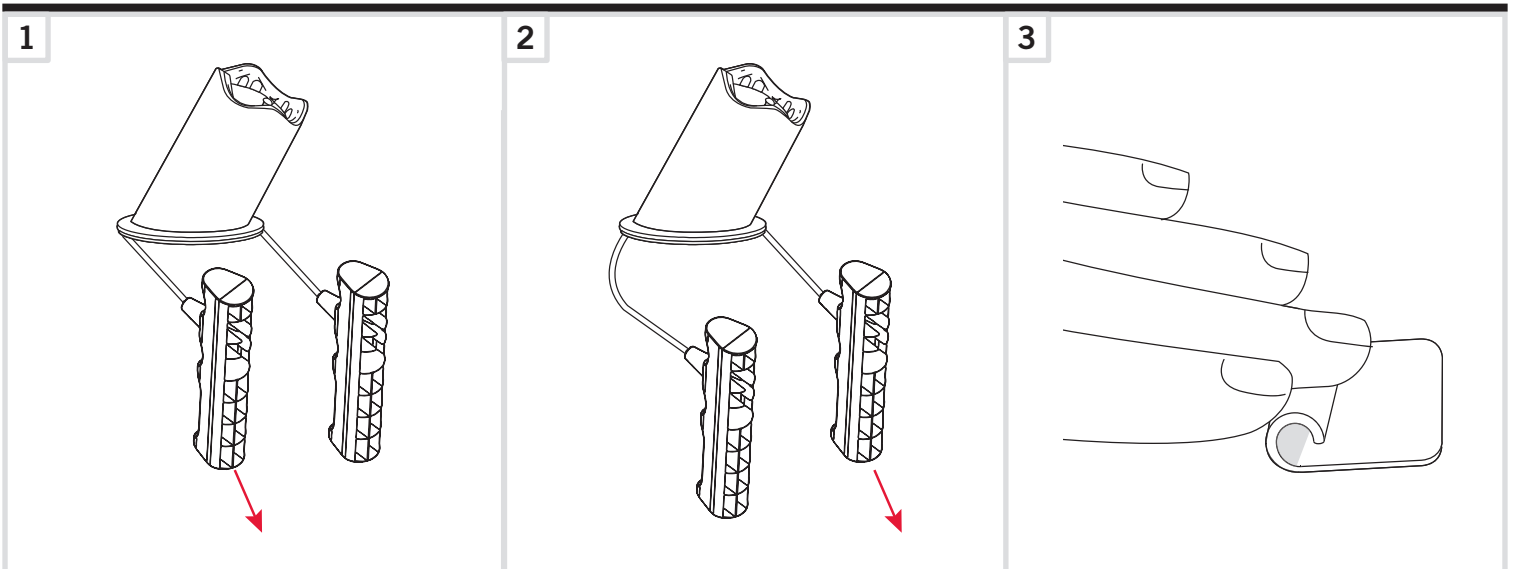

# OPTIONAL SECONDARY SENSOR

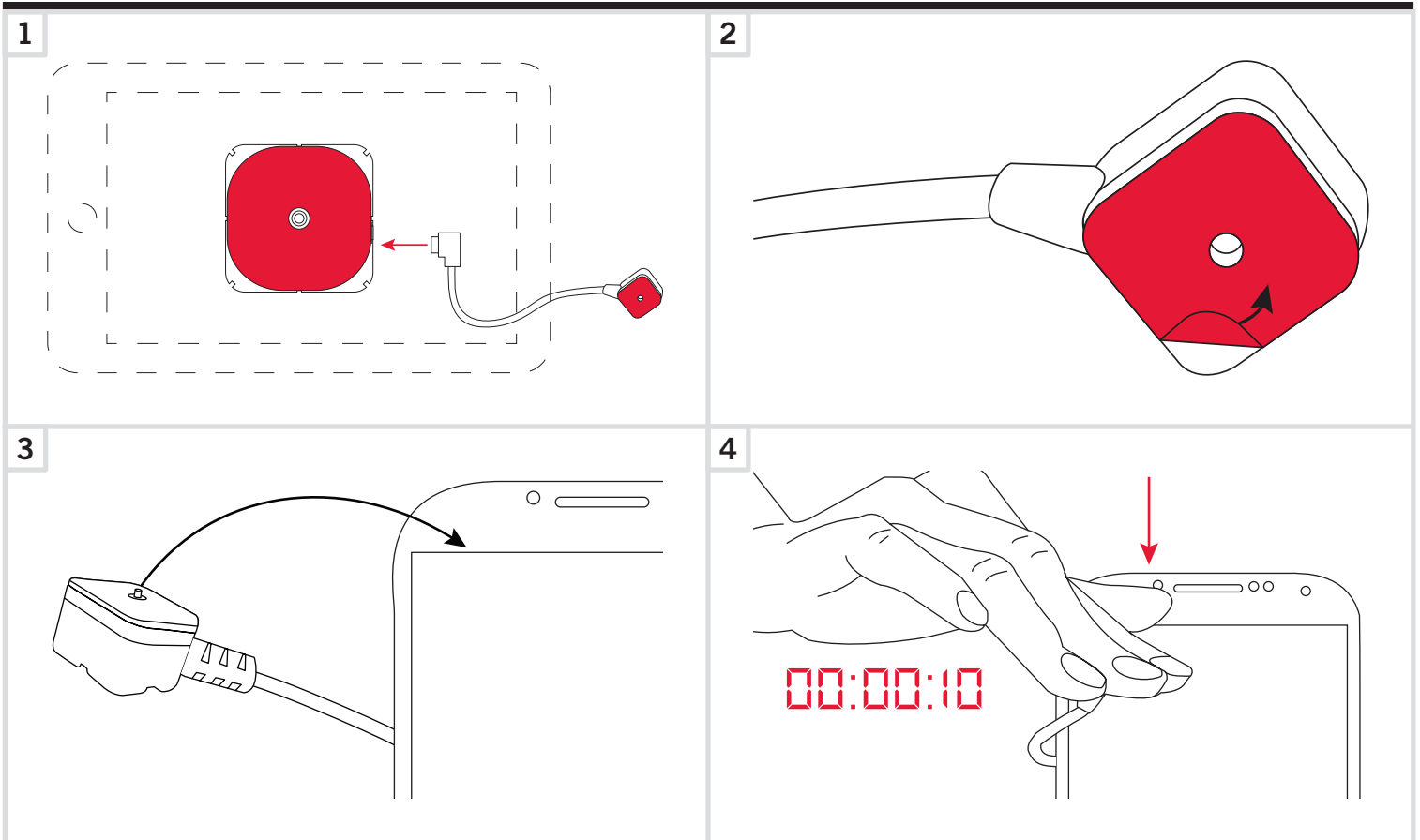

# SILENCING THE ALARM

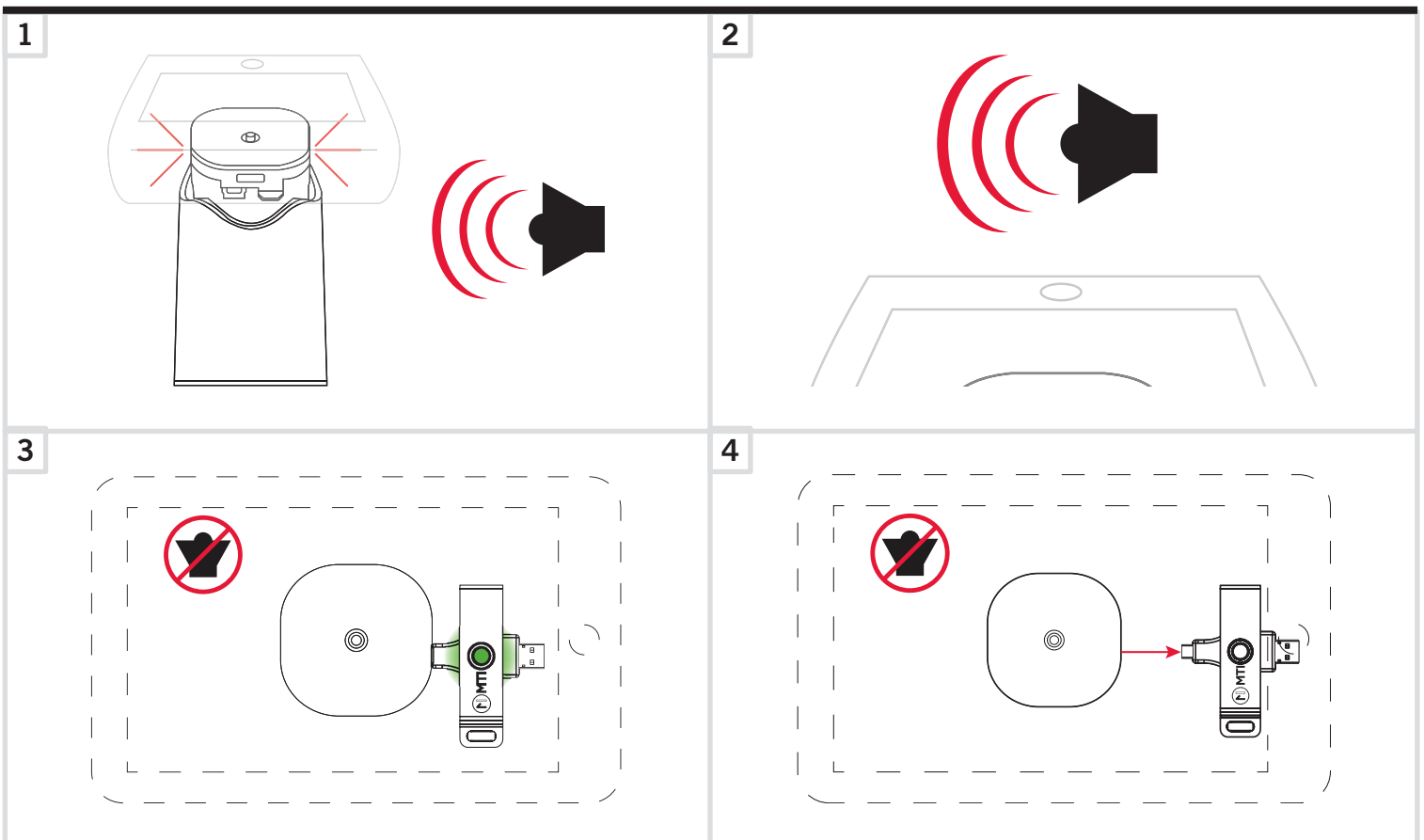

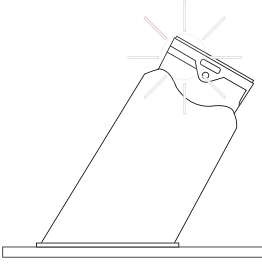
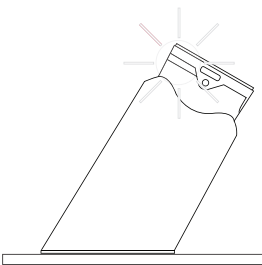
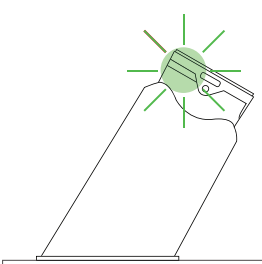
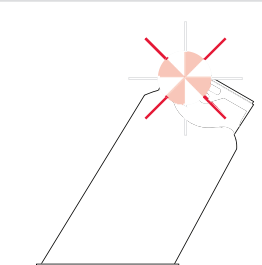
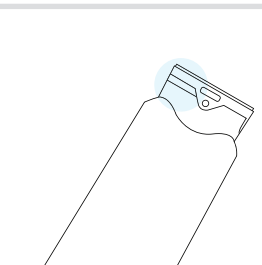
Visual Reference	System Status	Condition	Solution
	<p>Puck white double flash every 8 seconds</p> <p>No audible alarm</p> <p>Puck seated in riser</p>	Power is on, puck is disarmed	Mount customer product and learn system
	<p>Puck LEDs solid white.</p> <p>No audible alarm.</p> <p>Puck seated in riser.</p>	Power is on, Puck is armed.	Reconnect power
	<p>Puck green double flash every 8 seconds</p> <p>No audible alarm</p> <p>Puck seated in riser</p>	Pairing sequence between Puck and base.	Pairing mode can take up to a minute
	<p>Puck flashes red and white</p> <p>Steady alarm</p>	Puck is in a state of alarm due to theft, tampering or improperly mounted customer product	<p>Insert IntelliKey to silence alarm</p> <p>Fix alarming condition (check mounted product)</p> <p>Remove IntelliKey</p>
	<p>Puck LED solid blue</p> <p>Alarm module LEDs are solid red</p> <p>No audible alarm</p> <p>Puck is seated in riser</p>	Short circuit in SmartCable or customer product	<p>Replace SmartCable</p> <p>If issue is not resolved, replace customer product</p>

**In order to maximize consumer shopping experience during open hours, consider the following steps to extend battery life:**

- **TURN OFF** or to put all displayed devices/SKUs in **SLEEP** mode for the off hours for your store.
- Lowering the brightness level (during open hours) on your devices by 15-20%

**If you experience any condition not listed above, please contact Customer Service at 1-800-426-6844, Opt. 1**

Seller warrants all Products manufactured by Seller to be free from defects in material and workmanship. Seller's warranty shall begin on the date of shipment to Customer. The length of the warranty is determined by the Product type as set forth below.

Base units, display puck assemblies (enclosure and ECB, excluding puck battery), alarm modules (enclosure and ECB), Piezo alarms, secondary sensors, electronic security sensors, quad cables, power/data link cables, IntelliKey Switch Module assemblies, Keyswitch assemblies, Keypad assemblies, puck adapters and custom design brackets/adapters for the Freedom™ Consumer Electronic Handheld (CEhh) Merchandising System ("Freedom™ System"), and NFC electronics boards in the Freedom™ System, all OnSite® switching modules and video/audio switching and distribution modules for the Audition Signal Management System ("Audition System"), multimedia players, format converters, resolution scalers and audio/video cables for the Audition System are warranted for a period of one (1) year.

CarbonTether™ assemblies, both powered and mechanical and SmartTether™ assemblies are warranted for a period of one (1) year.

AirTether™ assemblies are warranted for a period of six (6) months.

Seller provides no warranty hereunder for Power Supplies, and Customer must rely solely upon any warranty provided by the manufacturer of such Power Supplies. Certain manufacturer warranties are on file with Seller and may be made available upon Customer's request. Seller warrants all batteries to be free from defects in materials and factory workmanship, and warrants any battery that fails to perform as specified within six (6) months after date of shipment. This warranty shall not apply if buyer fails to notify MTI of such defect within ten (10) days after discovery, or if battery has been subjected to misuse, negligence or accident.

The following components of the Freedom™ System are considered consumable items and Seller provides no warranty for such items: USB interconnect cables, extension cables, SmartCables, FlexSensors, Membrane Sensors, anti-skid pads, anti-rotation brackets, VHB adhesive pads, X- and L-brackets, CC- and DC-brackets, cable clamps, zip ties, and installation, retrieval and removal tools. Unused SmartCables and Secondary Sensors that are demonstrated by Customer to have been faulty upon delivery to Customer will be replaced at Seller's expense; provided, however, Customer shall be responsible for any and all related shipping and handling costs.

All other Seller-manufactured Products, not specified above, are warranted for a period of one (1) year.

Seller's warranty expressed herein does not apply to the following:

- Cartons, cases, cabinets, displays, or any other unit attached to or otherwise connected to a Seller-manufactured Product.
- The labor and other costs associated with the removal and replacement of the warranted Product or any component thereof.
- Products used in applications beyond their normal intended use, application, or rated specifications.
- Products damaged by accident, abuse, improper voltage, faulty installations, mechanical failure, fire, flood, lightning, civil unrest, or any act of God.
- Warranty services rendered by any party other than Seller unless so authorized by Seller.
- Replacement parts and equipment that have been discontinued or are otherwise unavailable.
- Products from other manufacturers that are integrated by Seller into Customer's system(s) are not warranted by Seller and are subject only to that warranty, if any, provided by the manufacturer of such Product(s).

Subject to the limitations stated herein, and at Seller's sole discretion, Seller will replace or repair defective Products or components thereof at no charge to Customer so long as Customer's account with Seller is current and Customer has returned the Product(s) or component thereof pursuant to a properly issued Return Material Authorization.

Replacement of any Product or any component thereof by Seller under this warranty provision shall not extend, in any way, the length of the original applicable warranty period otherwise provided for herein.

Seller reserves the right to replace a defective Product or component thereof with a refurbished Product or component.

Seller's warranty herein is non-transferable and shall extend only to Customer.