

1

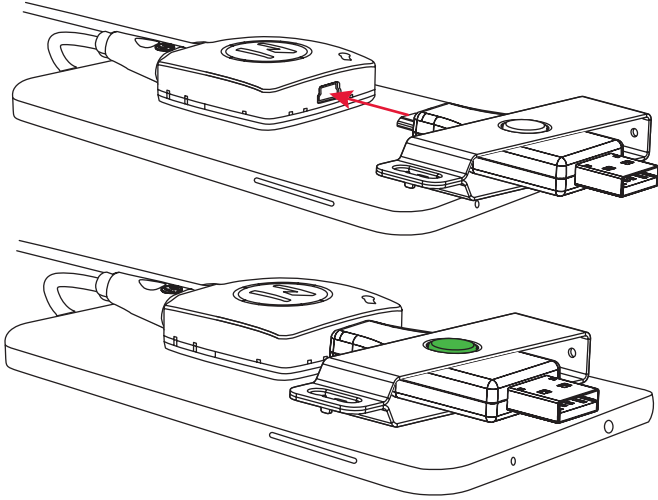

2

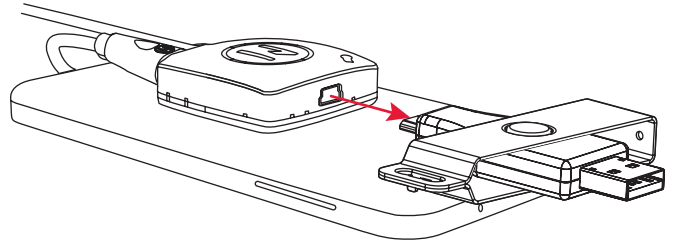

3

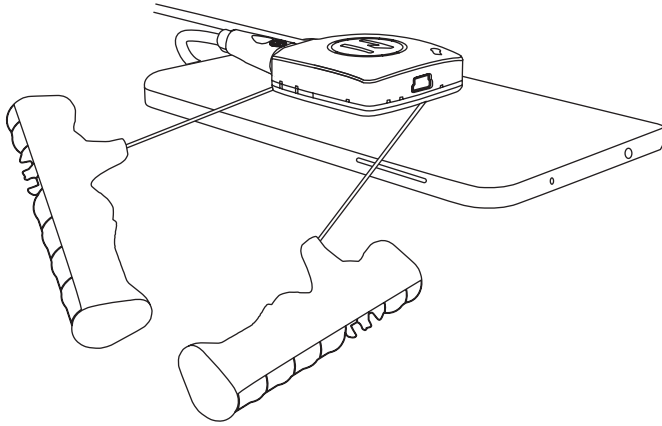

Use fingers to roll off any remaining VHB

4

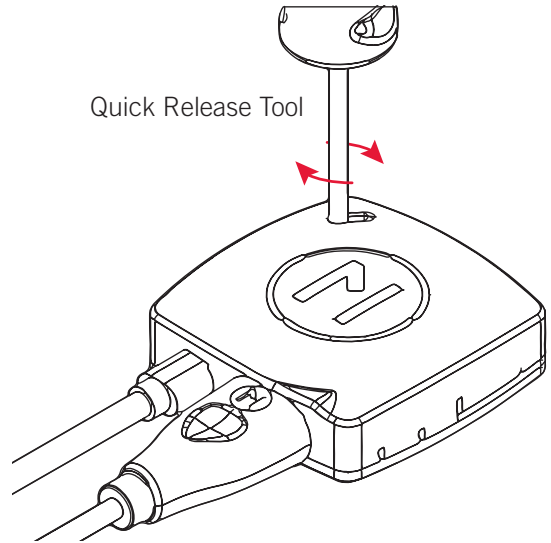

5

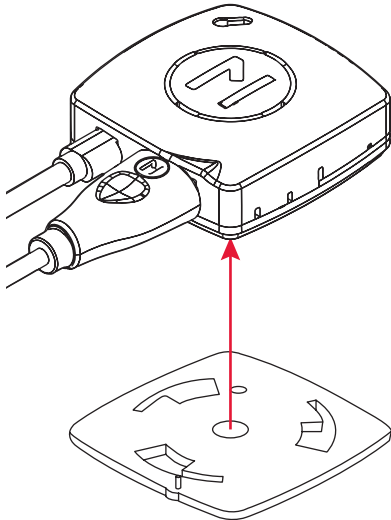

6

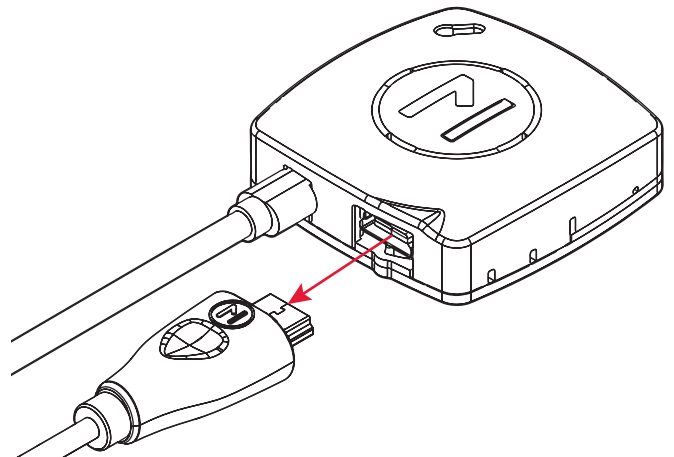

7

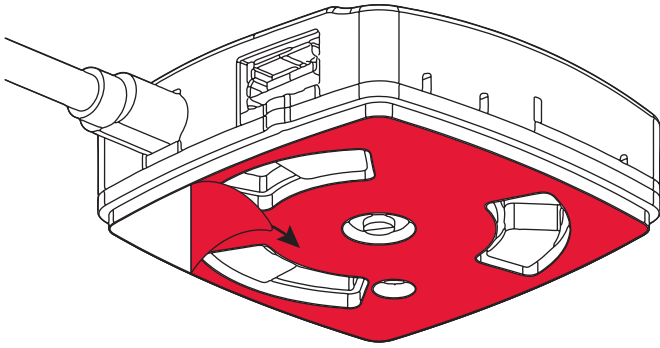

8

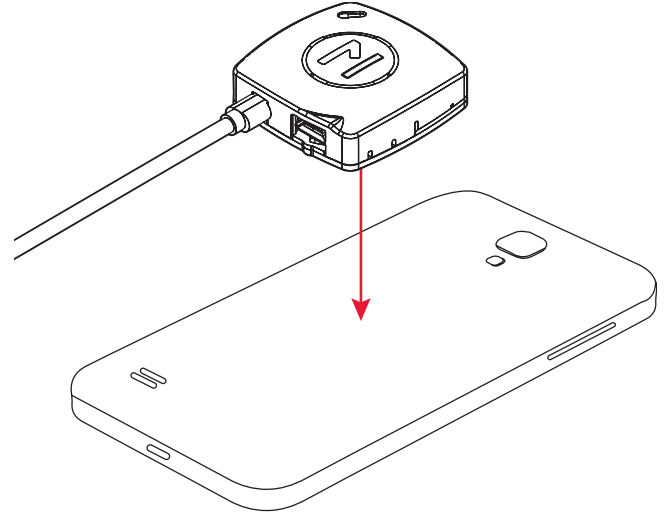

9

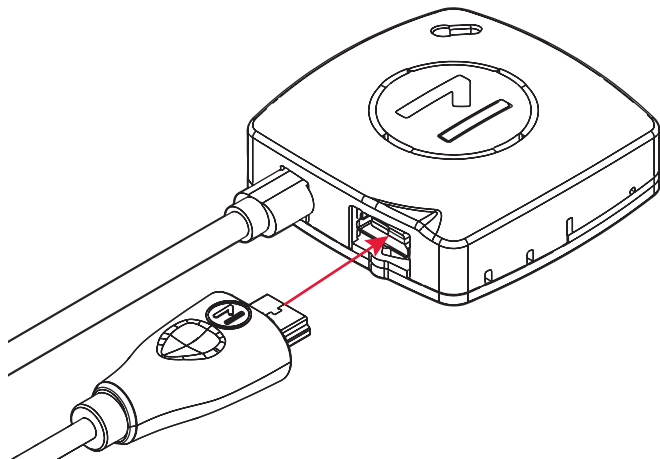

10

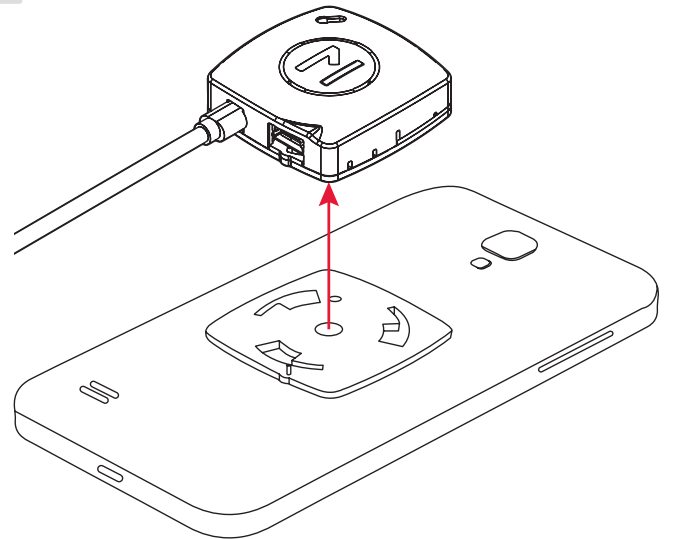

11

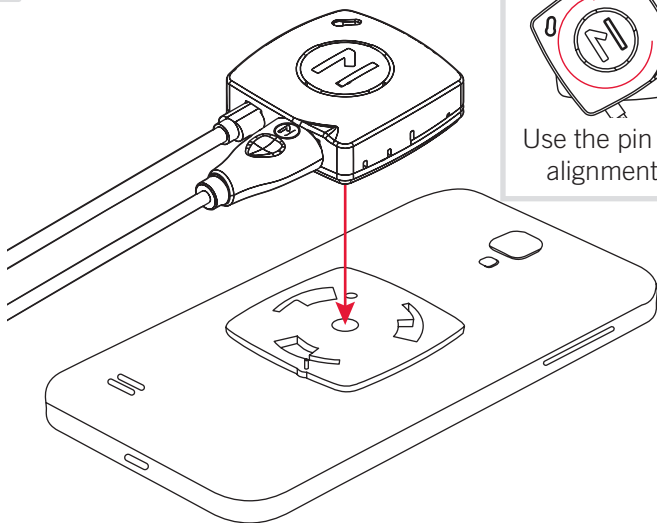

12

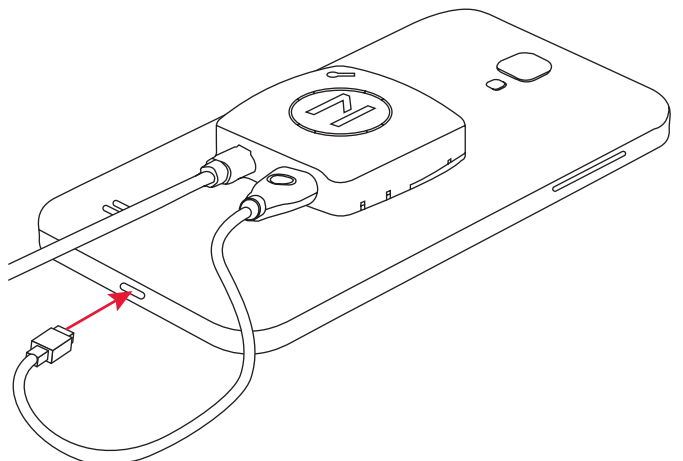

1

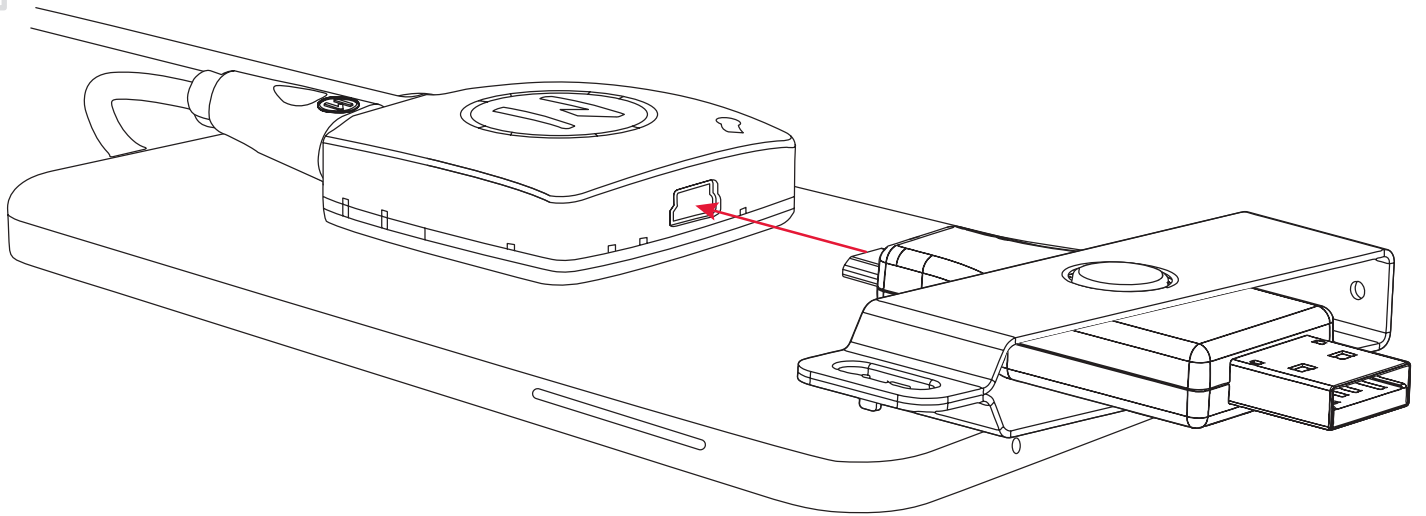

2

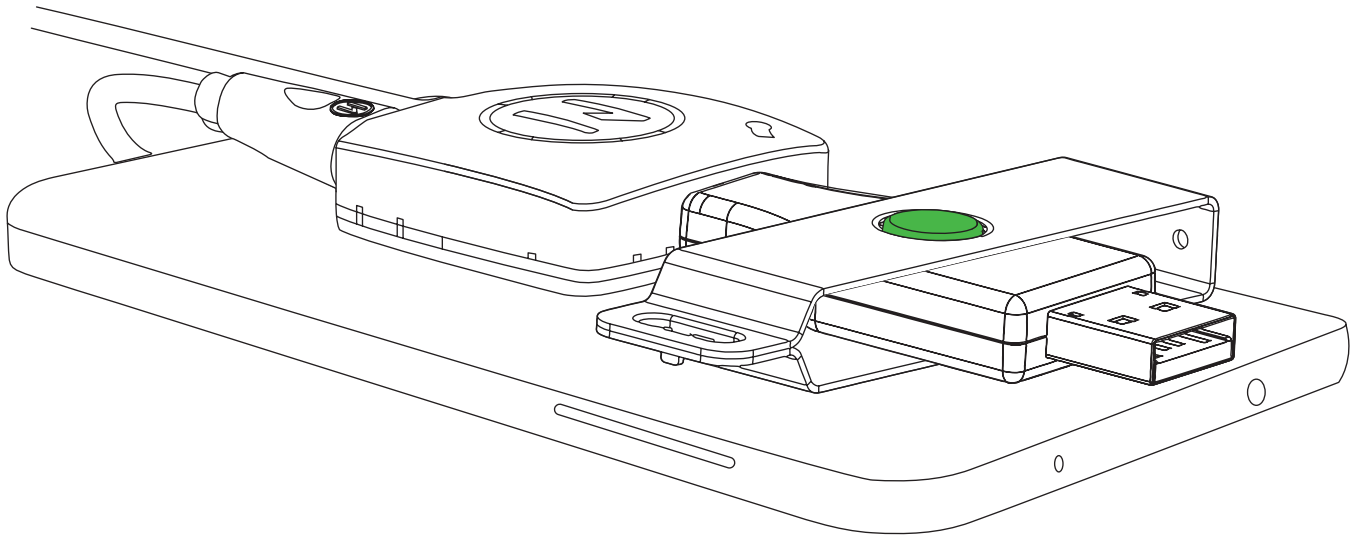

3

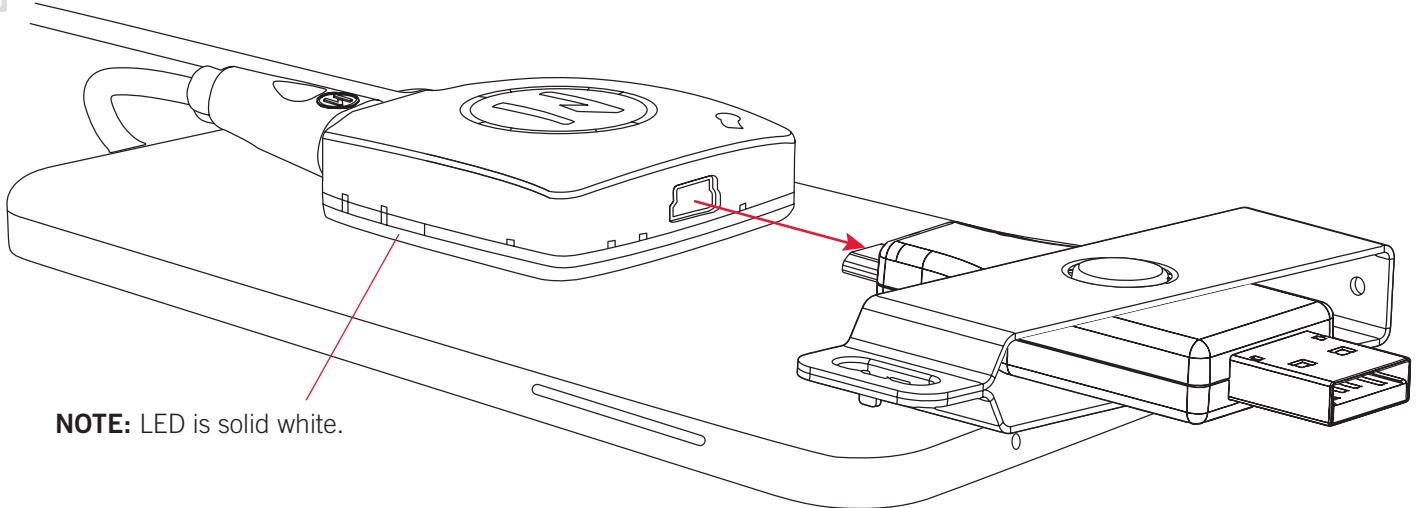

**NOTE:** LED is solid white.

1

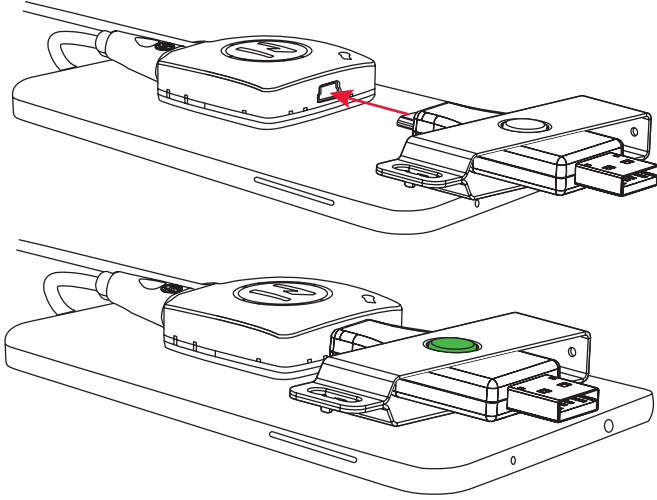

2

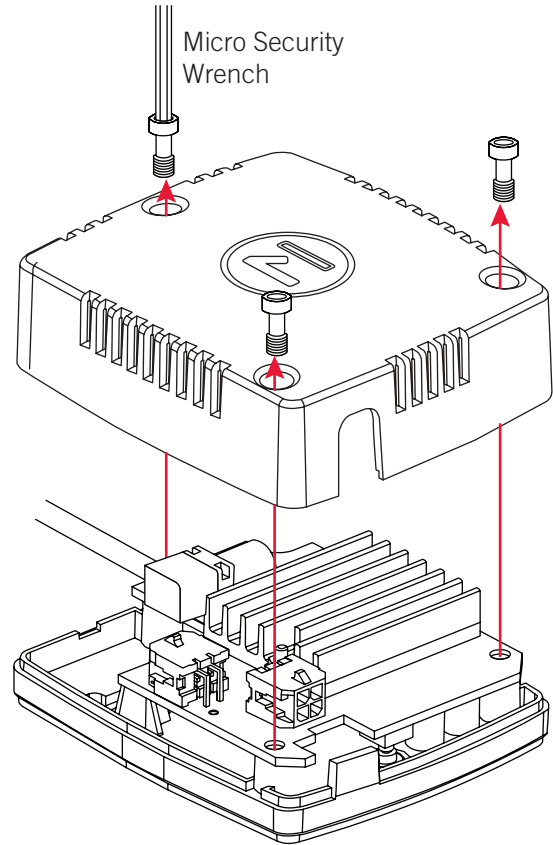

3

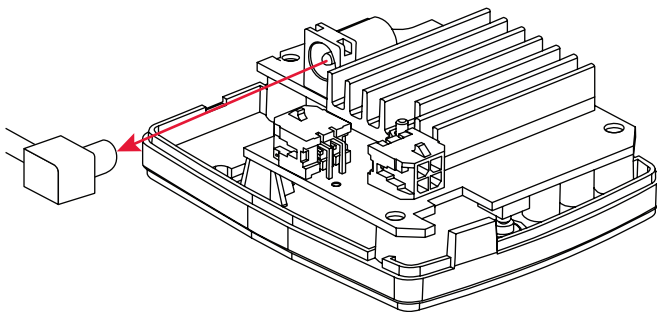

4 IF VHB OPTION WAS USED:

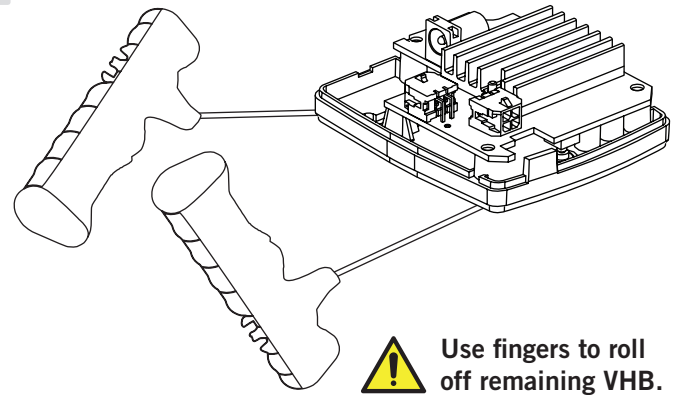

IF SCREW DOWN OPTION WAS USED:

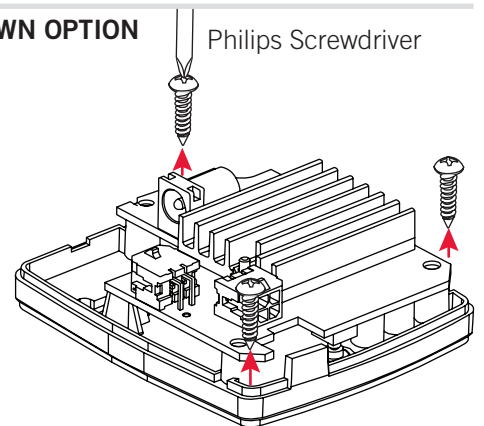

### 6 Note: New Anchor

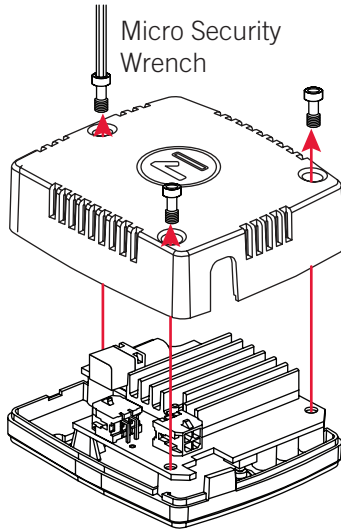

### 7a IF USING VHB OPTION:

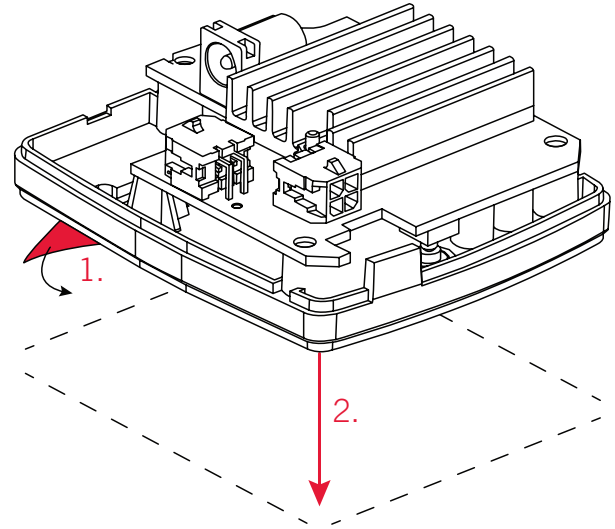

### 7b IF USING SCREW DOWN OPTION:

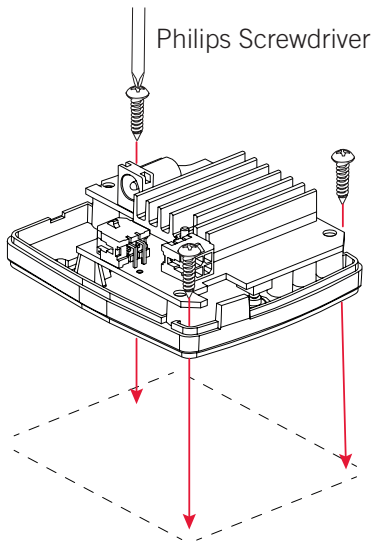

### 8

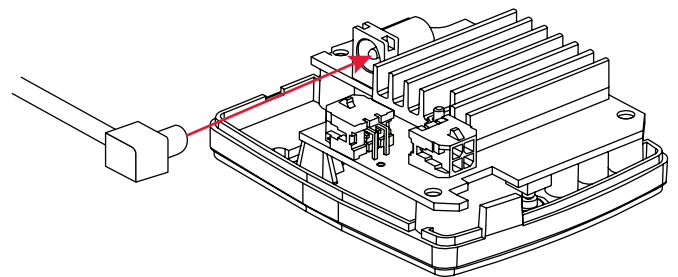

### 9

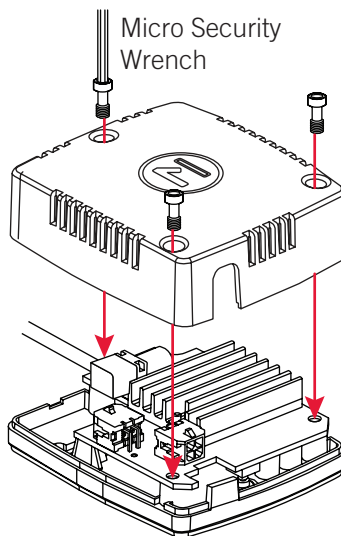

### 10

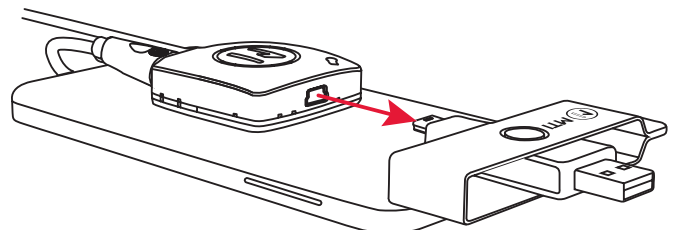

## VHB Option

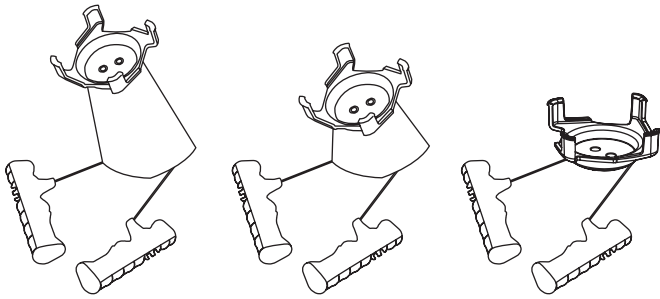

## Cup Riser Screw Down Option

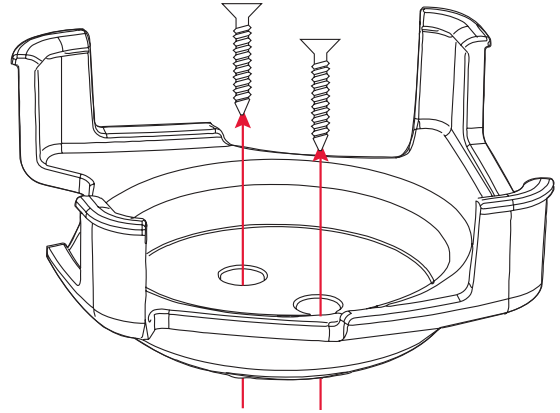

### 1 Short and Tall Riser Screw Down Option

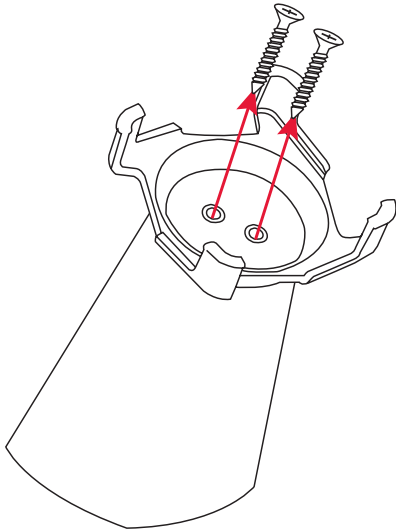

### 2

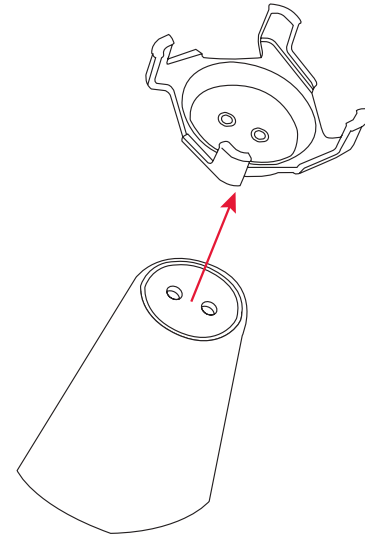

### 3

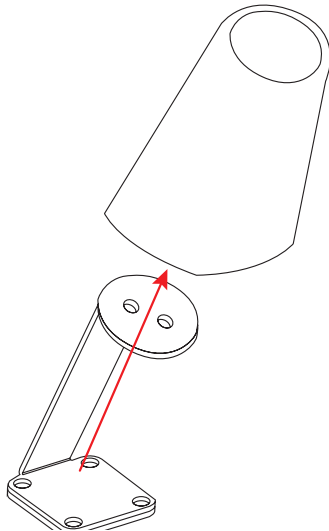

### 4

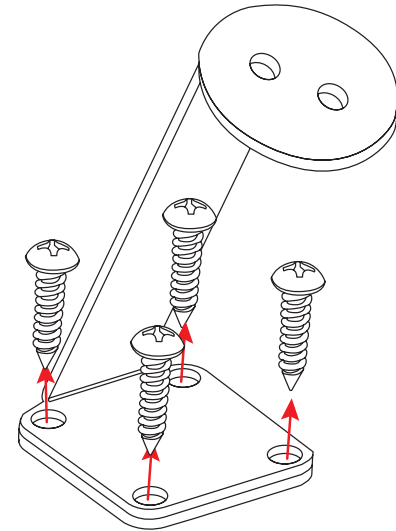

1

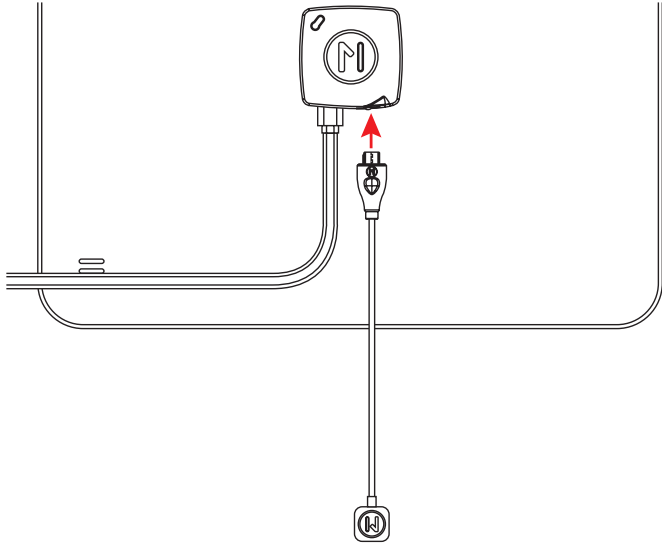

2

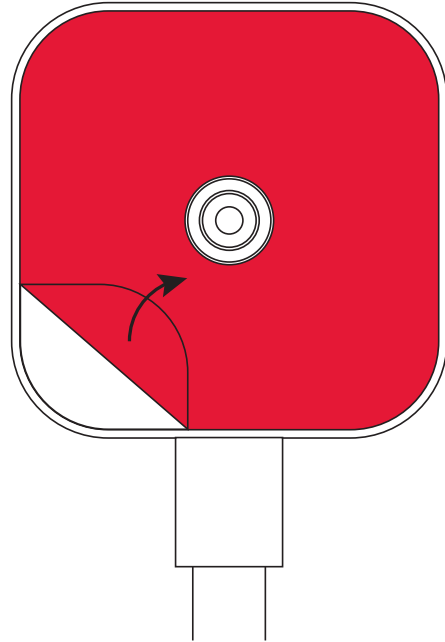

3

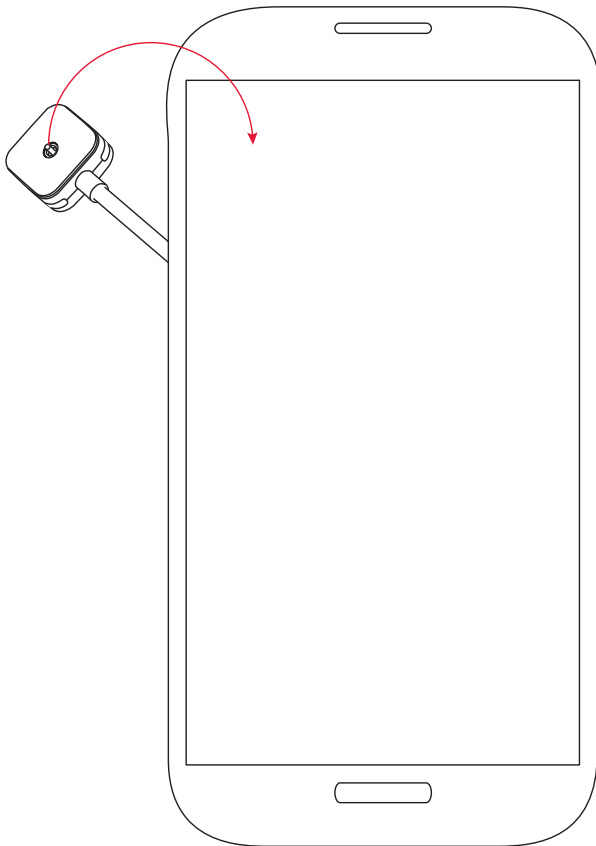

4

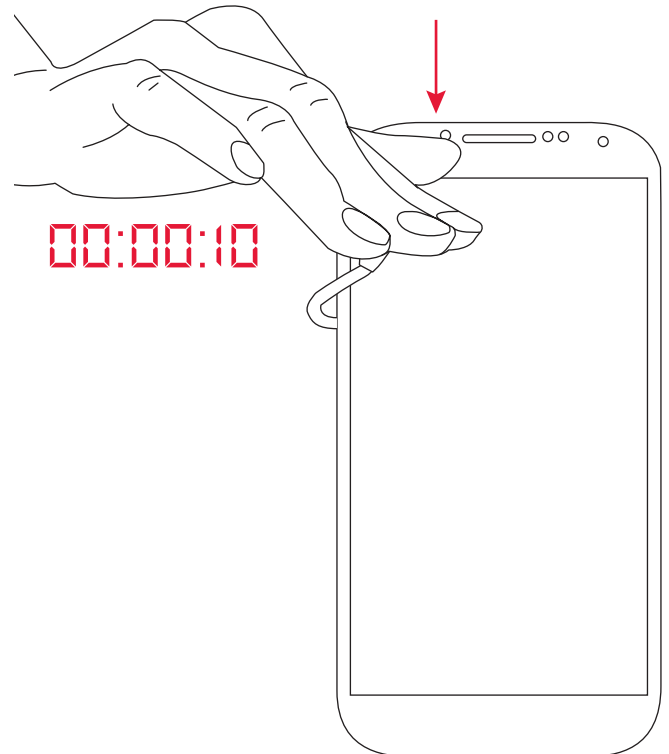

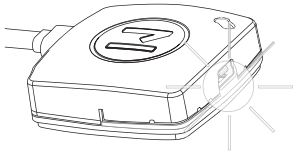
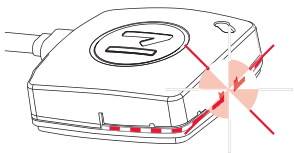
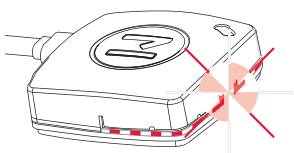
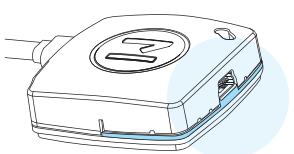
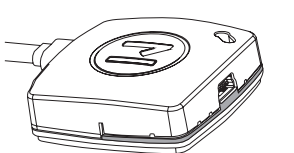
Visual Reference	System Status	Condition	Solution
	Sensor white double flash every 8 seconds No audible alarm	Power is on, Sensor is disarmed	Mount customer product and program/arm system
	Sensor flashes red and white Steady alarm	Sensor is in a state of alarm due to theft, tampering or improperly mounted customer product	Insert IntelliKey to silence alarm Fix alarming condition (check mounted product) Remove IntelliKey
	Sensor flashes red and white No audible alarm	Sensor has been alarming for more then 10 minutes.	Insert IntelliKey to silence alarm Fix alarming condition (check mounted product) Remove IntelliKey
	Sensor LED solid blue No audible alarm	Short circuit in GeniusCable or over current from the device	Replace GeniusCable If issue is not resolved, the device is too power hungry for Freedom Core II™ system and cannot be merchandised with it
	Five double-beeps Lights off	System is in a state of battery back-up mode <b>SYSTEM CANNOT BE PROGRAMMED IN THIS STATE</b>	Reconnect power

In order to maximize consumer shopping experience during open hours, consider the following steps to extend battery life:

- TURN OFF or put all displayed devices/SKUs in SLEEP mode for the off hours for your store.
- Lowering the brightness level (during open hours) on your devices by 15-20%

If you experience any condition not listed above, please contact Customer Service at 1-800-426-6844, Opt. 1



Seller warrants all Products manufactured by Seller to be free from defects in material and workmanship. Seller's warranty shall begin on the date of shipment to Customer. The length of the warranty is determined by the Product type as set forth below.

Base units, display puck assemblies (enclosure and ECB, excluding puck battery), alarm modules (enclosure and ECB), Piezo alarms, secondary sensors, electronic security sensors, quad cables, power/data link cables, IntelliKey Switch Module assemblies, Keyswitch assemblies, Keypad assemblies, puck adapters and custom design brackets/adapters for the Freedom™ Consumer Electronic Handheld (CEhh) Merchandising System ("Freedom™ System"), and NFC electronics boards in the Freedom™ System, all OnSite® switching modules and video/audio switching and distribution modules for the Audition Signal Management System ("Audition System"), multimedia players, format converters, resolution scalers and audio/video cables for the Audition System are warranted for a period of one (1) year.

CarbonTether™ assemblies, both powered and mechanical and SmartTether™ assemblies are warranted for a period of one (1) year.

AirTether™ assemblies are warranted for a period of six (6) months.

Seller provides no warranty hereunder for Power Supplies, and Customer must rely solely upon any warranty provided by the manufacturer of such Power Supplies. Certain manufacturer warranties are on file with Seller and may be made available upon Customer's request. Seller warrants all batteries to be free from defects in materials and factory workmanship, and warrants any battery that fails to perform as specified within six (6) months after date of shipment. This warranty shall not apply if buyer fails to notify MTI of such defect within ten (10) days after discovery, or if battery has been subjected to misuse, negligence or accident.

The following components of the Freedom™ System are considered consumable items and Seller provides no warranty for such items: USB interconnect cables, extension cables, SmartCables, FlexSensors, Membrane Sensors, anti-skid pads, anti-rotation brackets, VHB adhesive pads, X- and L-brackets, CC- and DC-brackets, cable clamps, zip ties, and installation, retrieval and removal tools. Unused SmartCables and Secondary Sensors that are demonstrated by Customer to have been faulty upon delivery to Customer will be replaced at Seller's expense; provided, however, Customer shall be responsible for any and all related shipping and handling costs.

All other Seller-manufactured Products, not specified above, are warranted for a period of one (1) year.

Seller's warranty expressed herein does not apply to the following:

- Cartons, cases, cabinets, displays, or any other unit attached to or otherwise connected to a Seller-manufactured Product.
- The labor and other costs associated with the removal and replacement of the warranted Product or any component thereof.
- Products used in applications beyond their normal intended use, application, or rated specifications.
- Products damaged by accident, abuse, improper voltage, faulty installations, mechanical failure, fire, flood, lightning, civil unrest, or any act of God.
- Warranty services rendered by any party other than Seller unless so authorized by Seller.
- Replacement parts and equipment that have been discontinued or are otherwise unavailable.
- Products from other manufacturers that are integrated by Seller into Customer's system(s) are not warranted by Seller and are subject only to that warranty, if any, provided by the manufacturer of such Product(s).

Subject to the limitations stated herein, and at Seller's sole discretion, Seller will replace or repair defective Products or components thereof at no charge to Customer so long as Customer's account with Seller is current and Customer has returned the Product(s) or component thereof pursuant to a properly issued Return Material Authorization.

Replacement of any Product or any component thereof by Seller under this warranty provision shall not extend, in any way, the length of the original applicable warranty period otherwise provided for herein.

Seller reserves the right to replace a defective Product or component thereof with a refurbished Product or component.

Seller's warranty herein is non-transferable and shall extend only to Customer.