

- 1** Peel and stick the spacer onto the bottom of the inductive charger. Insert the inductive charger into designated slot on the watch stand.

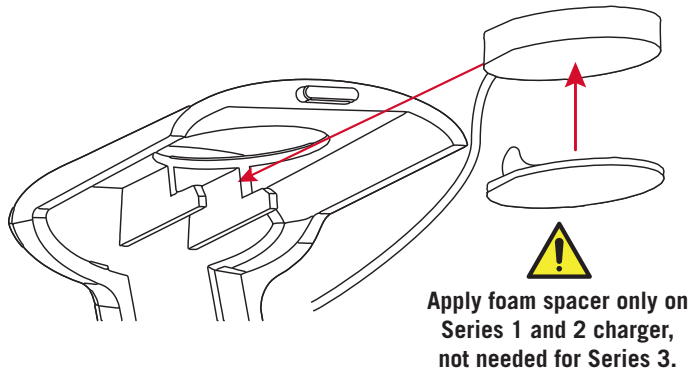

- 2** Route the cable down through the stand as shown.

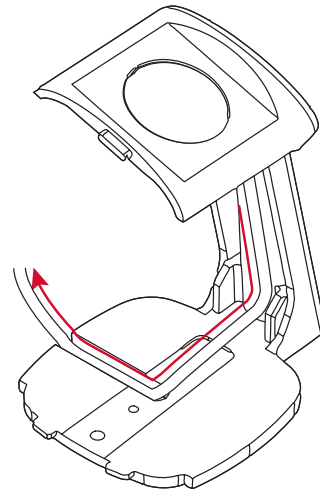

- 3** Slide the other half of the watch stand into place as shown. A slight clicking noise will indicate the two halves are in place. Secure with a screw and Double-Sided System Tool as shown. Plug in the Apple Inductive Charger.

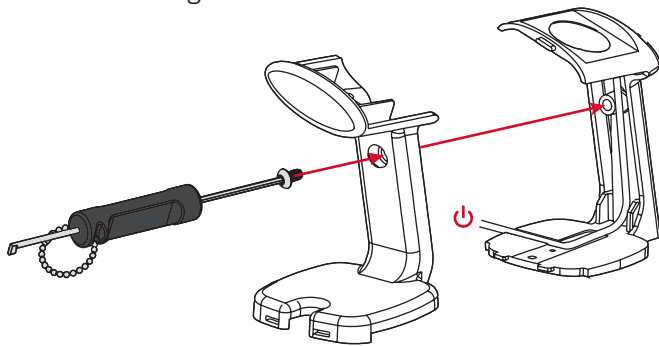

- 4** Remove backing of adhesive on the bottom of the watch stand. Place the watch stand in the desired location and allow 24 hours for complete adhesion.

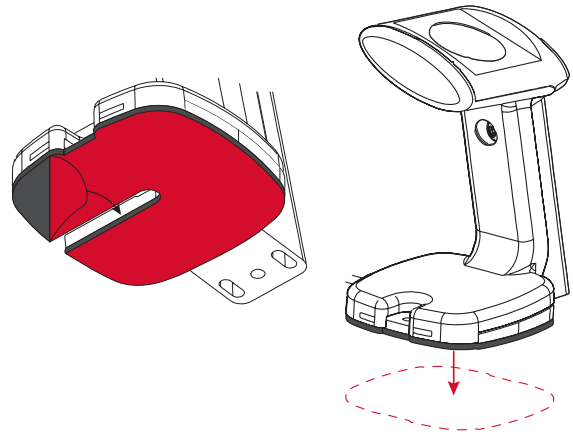

- 5** Insert Intellikey into the Alarm Module to disarm.

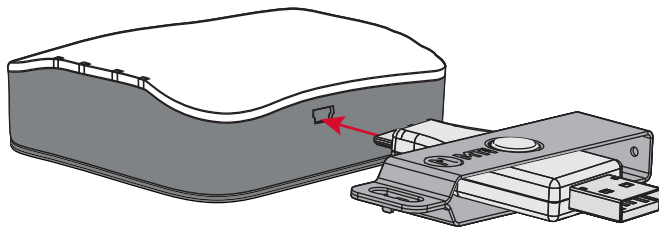

Insert IntelliKey to disarm.

- 6** Connect the FlexSensor cable to the Alarm module.

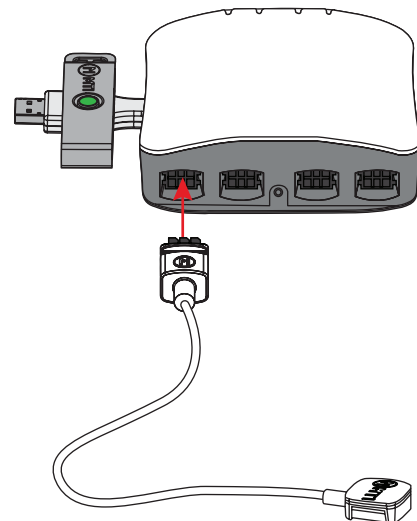

7 With the MTI logo on the FlexSensor and anchor facing up, fully insert golden finger end of FlexSensor into the bottom slot on the anchor housing of the FlexSensor Cable until the golden fingers are no longer visible and a slight clicking sound is heard.

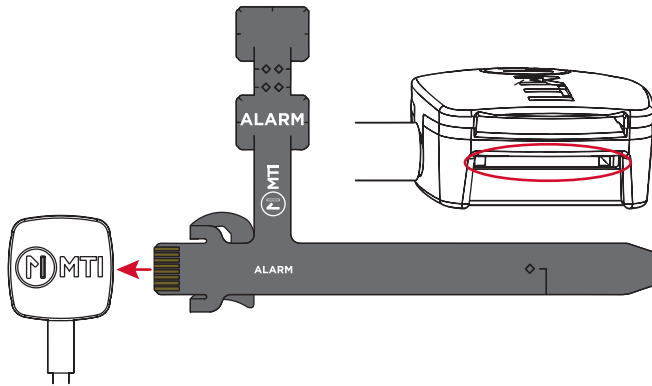

8 Remove backing of adhesive and press firmly onto the underside of anchor housing.

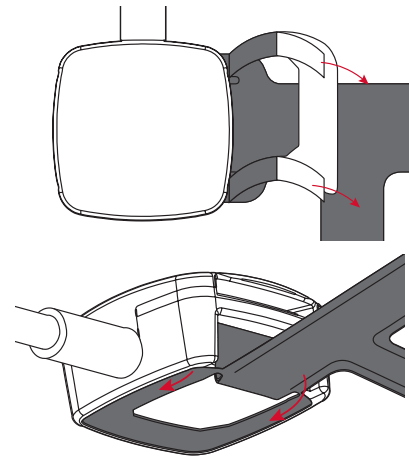

9 Remove backing of adhesive on the FlexSensor in preparation for attaching to back of watch.

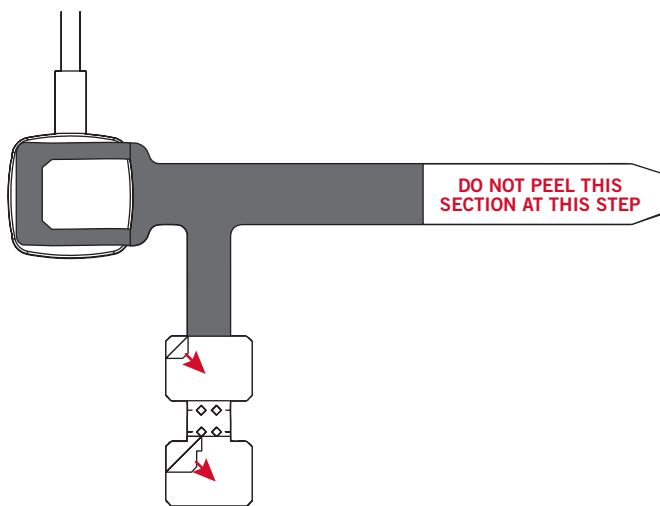

10 Firmly press FlexSensor adhesive side down on back of watch as shown.

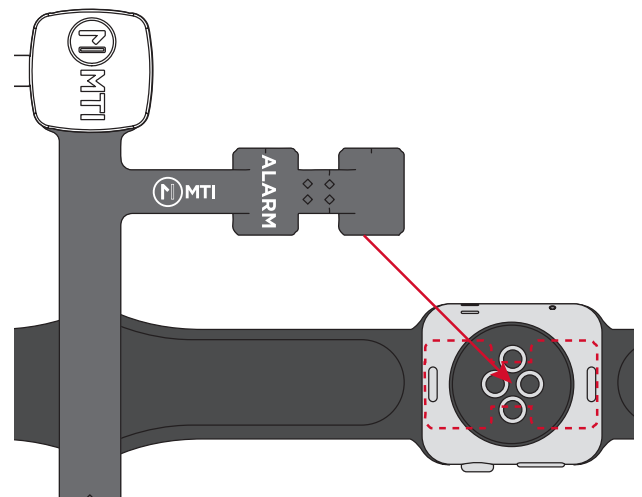

11 Turn watch over, wrap FlexSensor housing around watch band.

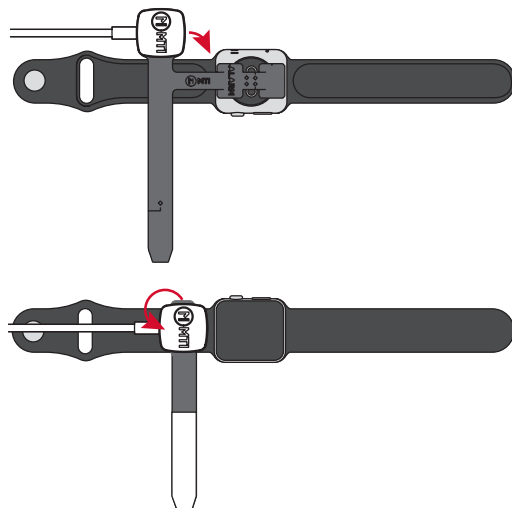

12 Wrap loop around and insert end of loop through anchor housing. Tighten FlexSensor, remove backing of adhesive and adhere to underside of sensor. There may be some excess material at the end which may be trimmed off. Remove Intellikey from Alarm Module to arm system.

