

Product Manual for
FREEDOM CORE II™
4-PORT ALARM MODULE

Contents

| | | |
|-----|----------------------------|----|
| 1. | Materials in Box | 2 |
| 2. | Standard Installation | 3 |
| 3. | Power Booster Installation | 4 |
| 4. | Daisy Chain Configuration | 5 |
| 5. | Sensor Merchandising | 6 |
| 6. | Disconnecting The Sensor | 7 |
| 7. | Sensor Removal | 8 |
| 8. | Arming The System | 9 |
| 9. | LED Troubleshooting | 10 |
| 10. | Removing/Replacing Vhb | 11 |
| 11. | Limited Warranty | 12 |

DO NOT REMOVE FROM STORE



**For additional support, please reach out to our
 Contact Center at 800-426-6844**

Core II 4-Port Alarm Module

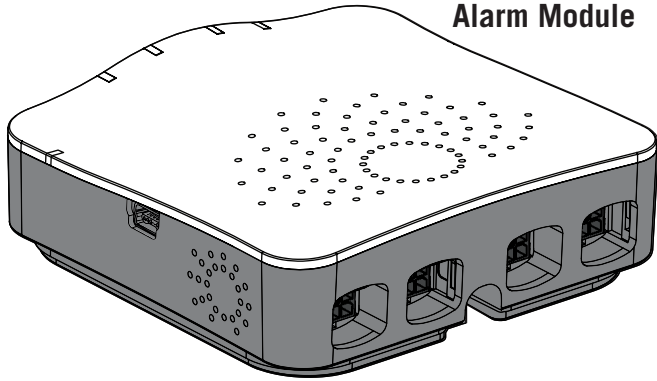

Optional Power Booster

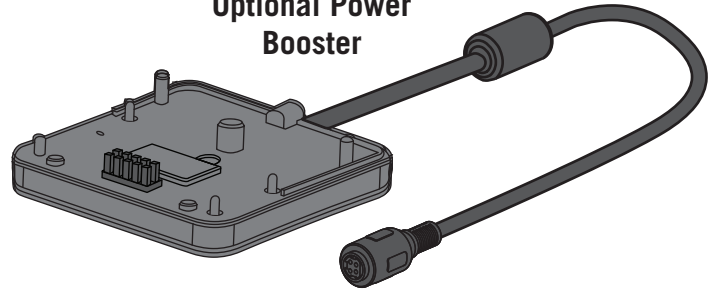

Power Supply

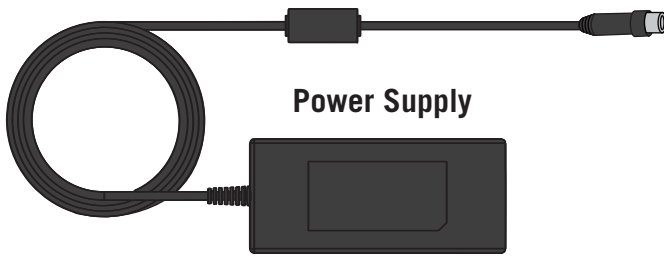

Mounting Plate

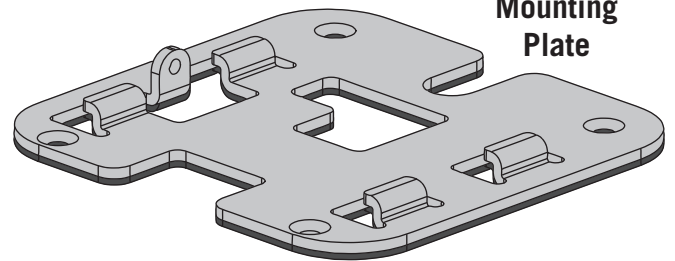

REQUIRED, BUT NOT INCLUDED

Power Supply Cable

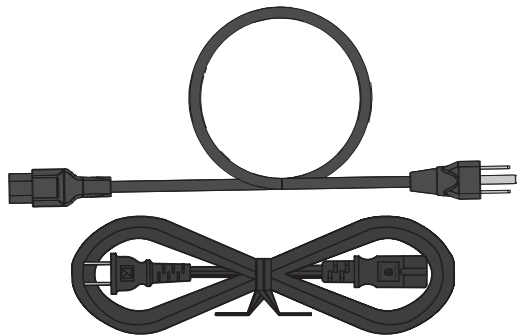

Double-Sided System Tool

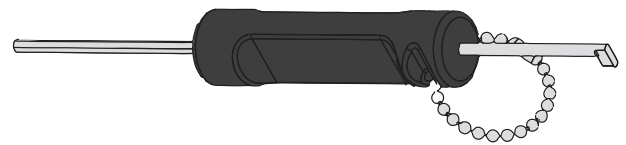

Phillips-Head Screwdriver

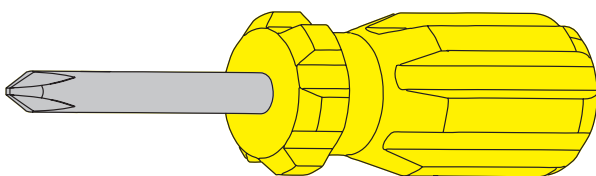

Merchandise Sensor (varies)

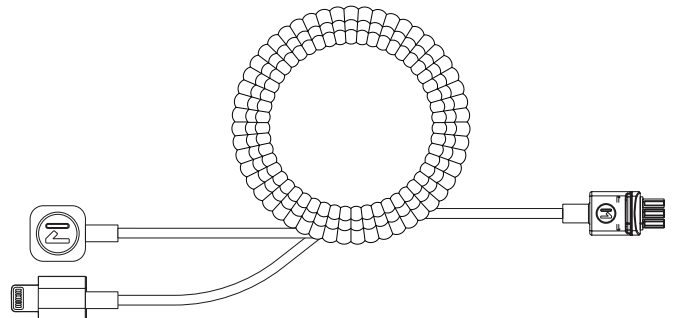

Required for screw down installations.

- 1** Place the Alarm Module Mounting Bracket by either peeling the red film off of the adhesive, or screw mounting the bracket into place. If using adhesive mount, clean fixture surface with alcohol wipe, allow it to dry, or dry with cloth before installation.

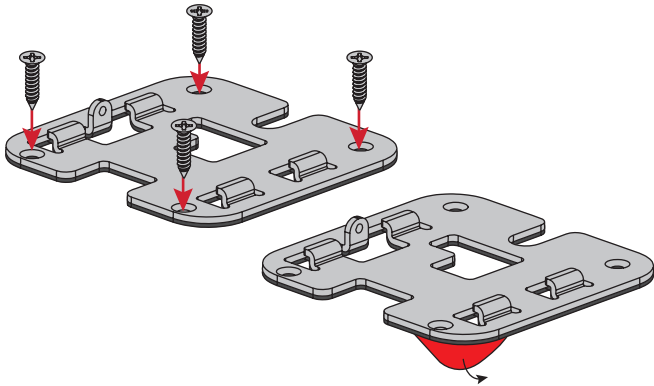

- 2** Connect the power supply output connector to the Alarm Module.

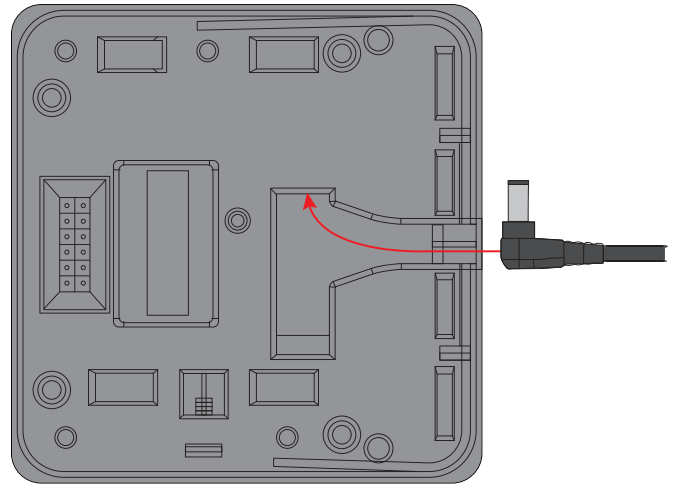

- 3** Slide the Alarm Module onto the bracket.

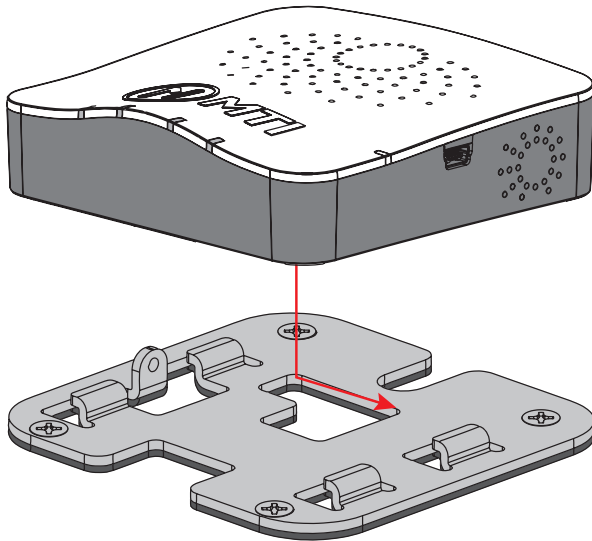

- 4** Secure the Alarm Module to the bracket with the Double-Sided System Tool.

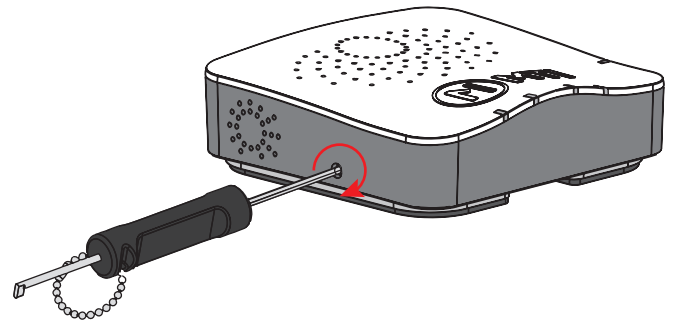

- 5** Connect the power cord to the power supply and plug the other end into the nearest outlet.

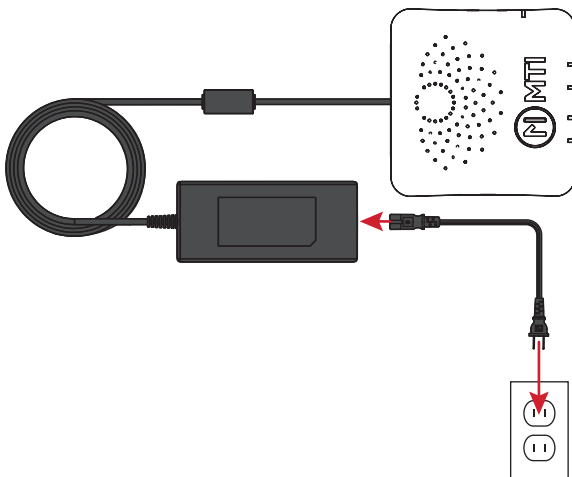

- 6**

See Page 5 for Daisy Chain Instructions, See Page 6 for Merchandising Instructions

- 1** Place the Alarm Module Mounting Bracket by either peeling the red film off of the adhesive, or screw mounting the bracket into place. If using adhesive mount, clean fixture surface with alcohol wipe, allow it to dry, or dry with cloth before installation.

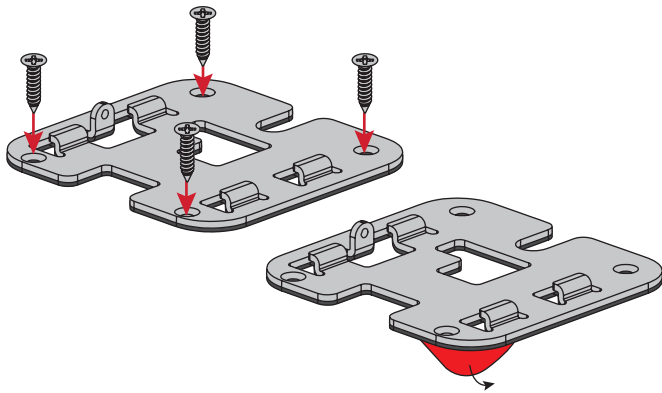

- 2** Connect the Power Booster to the Alarm Module and connect power to the Power Booster

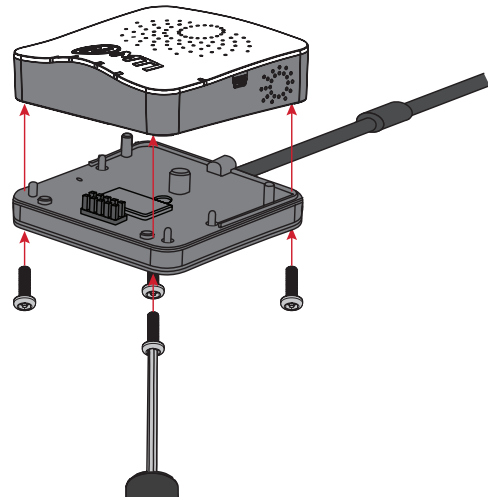

- 3** Slide the Alarm Module with Power Booster onto the bracket.

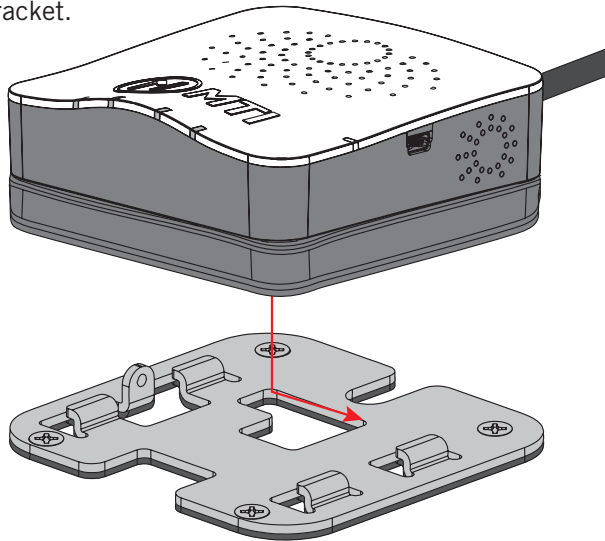

- 4** Secure the Alarm Module with Power Booster to the bracket with the Double-Sided System Tool.

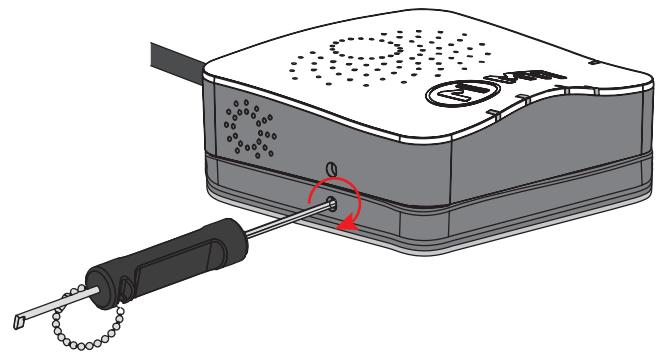

- 5** Connect the Power Booster power cable to the power supply output connector, plug the power cord into the power supply and plug the other end into the nearest outlet.

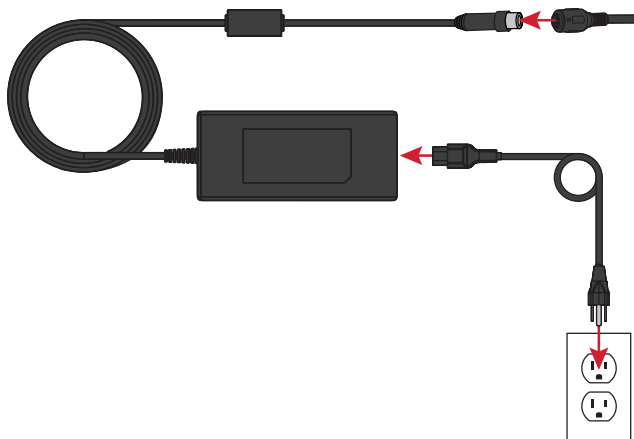

- 6**

See Page 5 for Daisy Chain Instructions, See Page 6 for Merchandising Instructions

**Supports up to 20 Alarm Modules
(80 devices) with one ISM**

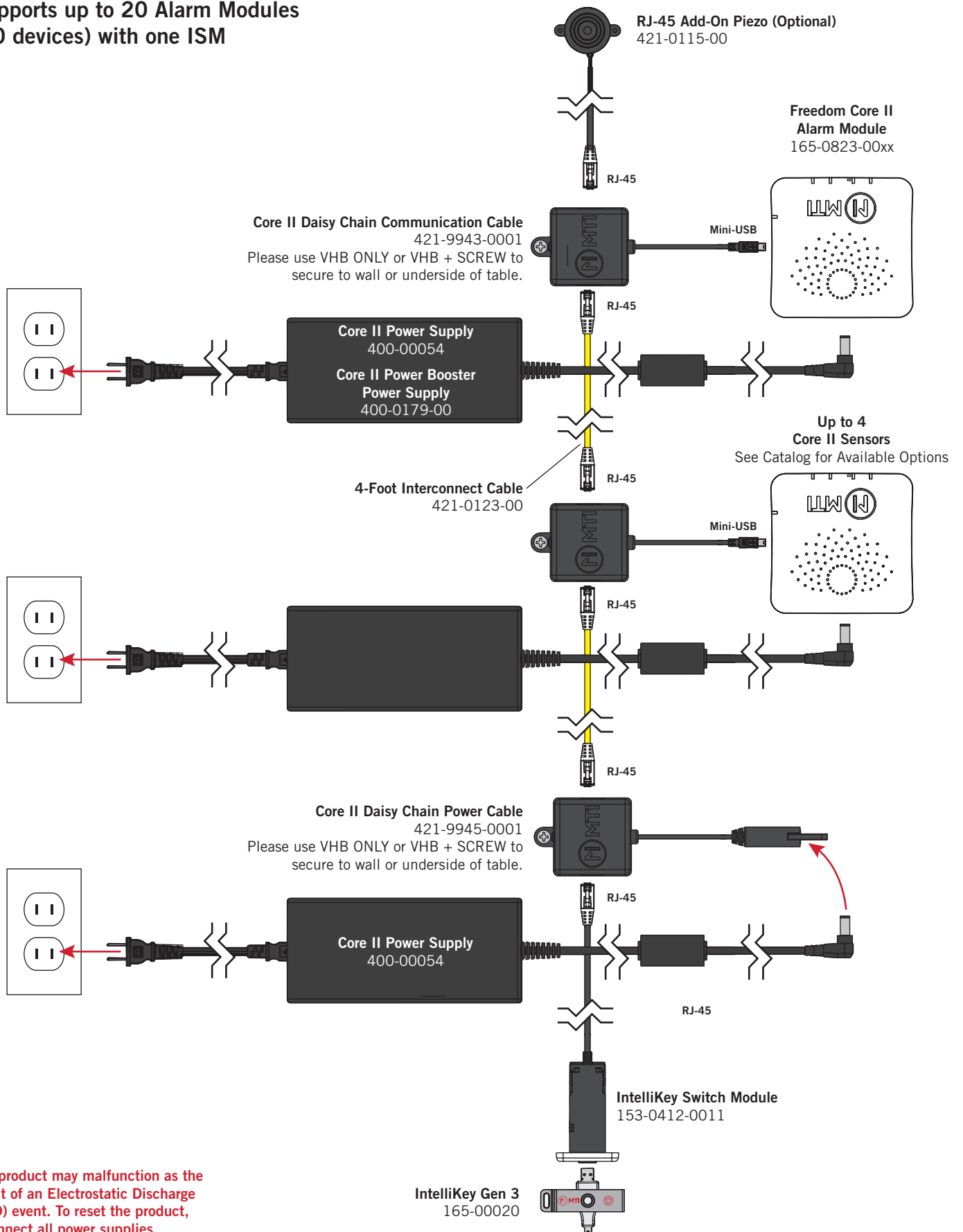

The product may malfunction as the result of an Electrostatic Discharge (ESD) event. To reset the product, reconnect all power supplies.

Connecting Sensors to the Alarm Module:

Plug desired sensor into port on the back of the Core II Alarm Module. Attach or insert other end to device (see the following three examples).

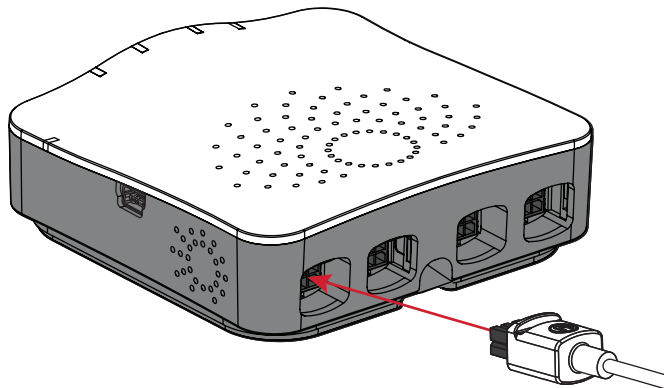

Alarm will sound if Sensors unplugged.

Powered Micro USB:

Powers and alarms Micro USB devices via a straight connector.

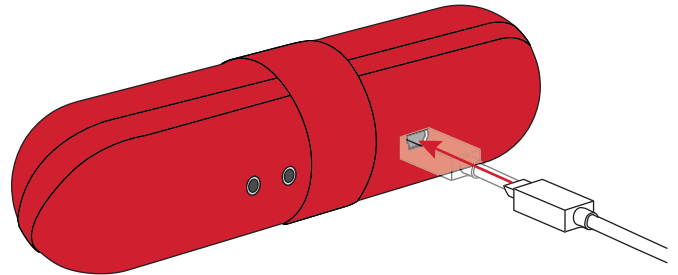

Powered Lightning w/ Mini-Disc Sensor:

Powers and alarms Apple devices via a lightning connector for power and a Mini-Disc sensor for Alarming. Clean the device with an alcohol wipe and allow to dry. Peel the red film from the VHB adhesive and press down firmly for 60 seconds. VHB will be fully secured in 24 hours to its maximum adhesion. Attempting to reposition will compromise the VHB integrity.

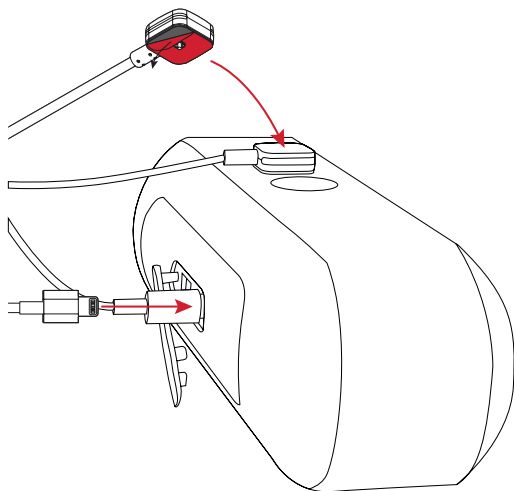

Please note that VHB adhesion takes 24 hours.

Mini-Disc Sensor:

Alarms any device not requiring power. Clean the device with an alcohol wipe and allow to dry. Peel the red film from the VHB adhesive and press down firmly for 60 seconds. VHB will be fully secured in 24 hours to its maximum adhesion. Attempting to reposition will compromise the VHB integrity.

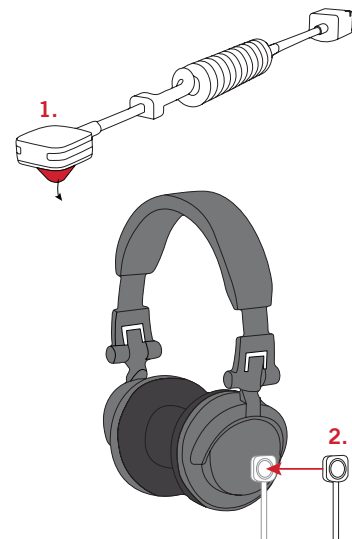

Please note that VHB adhesion takes 24 hours.

DISCONNECTING THE SENSOR

- 1** Insert the IntelliKey into the port on the side of the Alarm Module until the Intellikey's LED turns green.

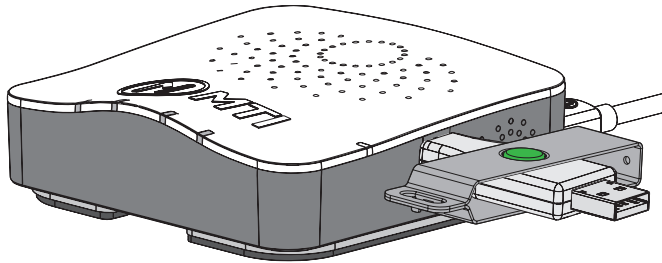

- 2** Insert the L shaped end of the Double-Sided System Tool into the slot on the Alarm Module and turn counter-clockwise.

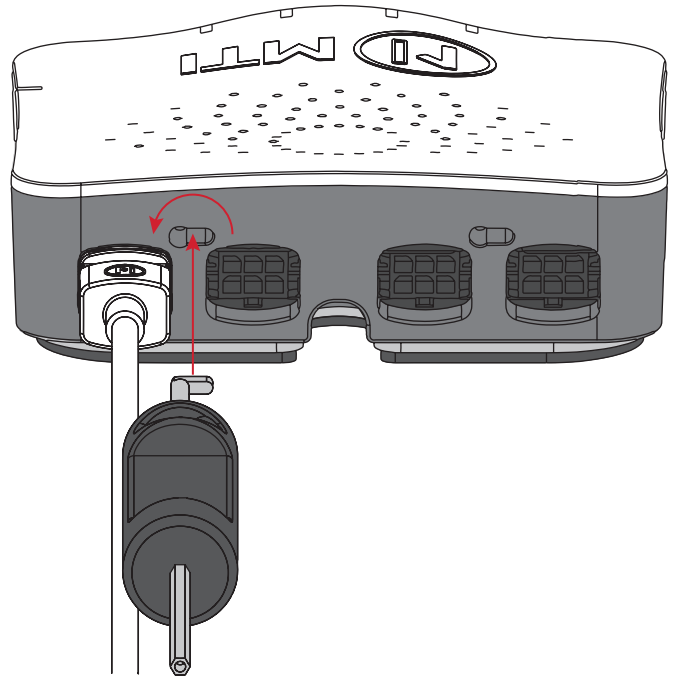

- 3** With the Double-Sided System Tool still in the Alarm Module, pull out the sensor.

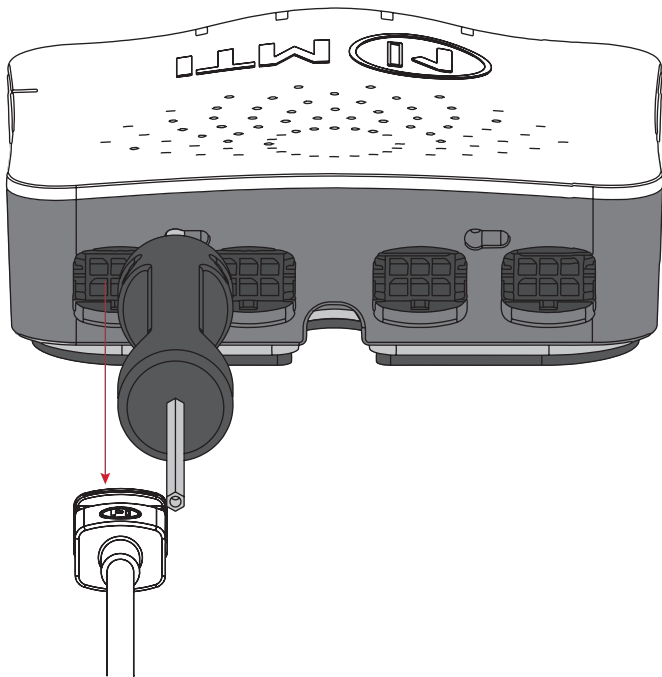

- 4** Remove the IntelliKey from the Alarm Module.

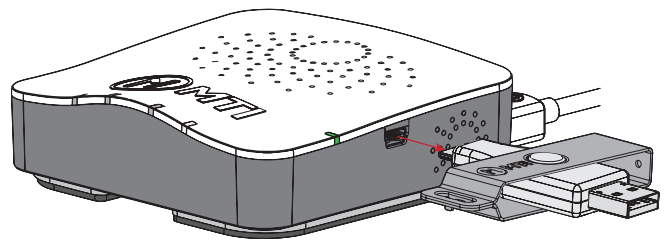

SENSOR REMOVAL

- 1** Hold the Adhesive Pad Removal Tool with both hands and using a sawing motion, pull one side of the tool, then the other back and forth. The thread will move through the VHB and release the sensor from the device.

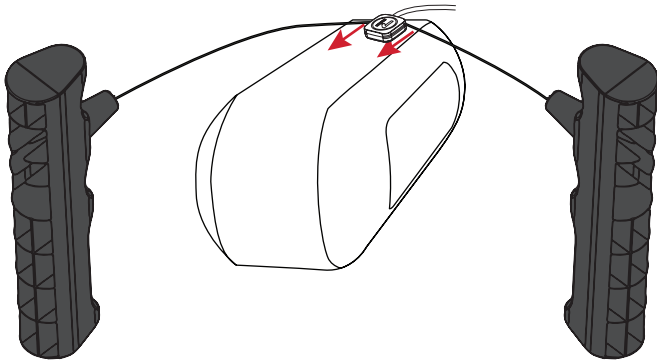

- 2** Remove excess VHB by rolling it off the sensor.

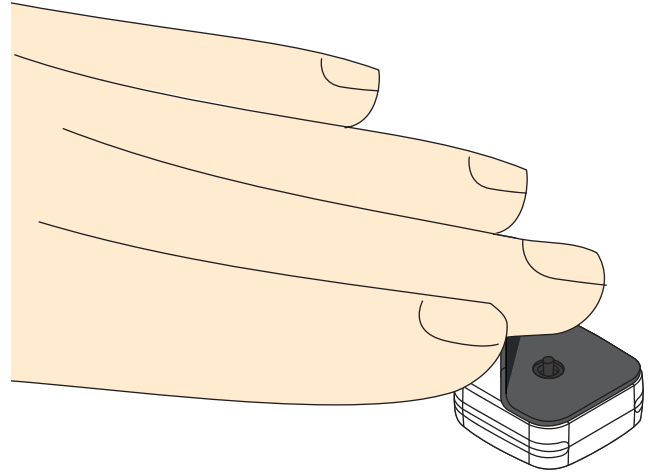

- 3** Remove excess VHB by rolling it off the device.

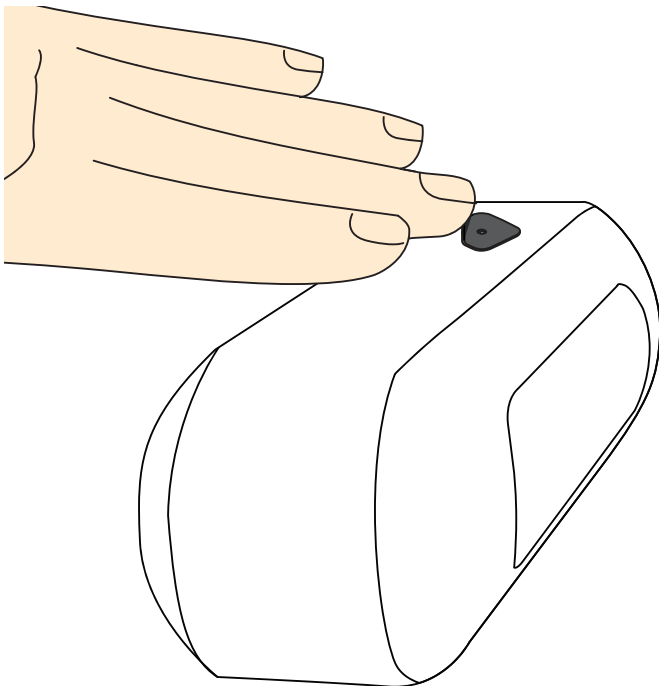

- 4** Clean the sensor with an alcohol wipe and allow to dry. Place new VHB on the sensor (if needed).

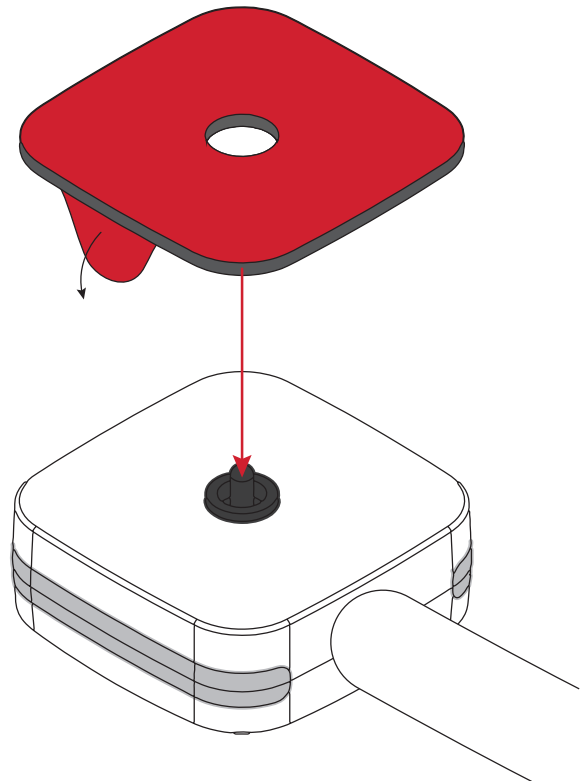

- 1 Insert IntelliKey into Alarm Module.

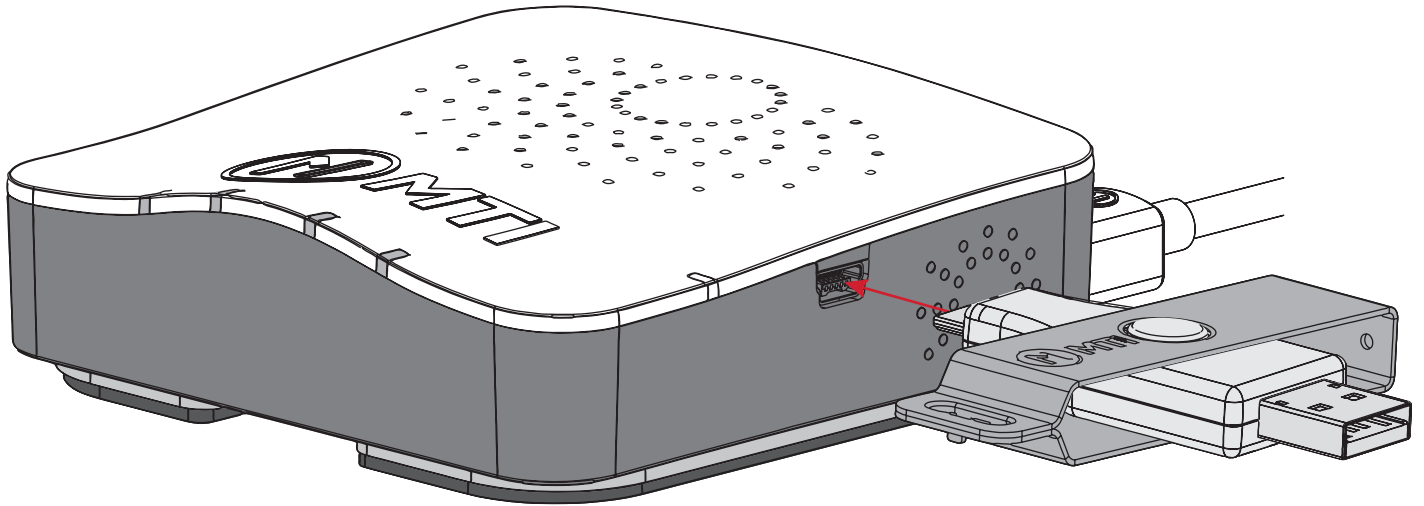

- 2 Wait until the IntelliKey LED turns green (about 5 seconds). This indicates that the system is armed.

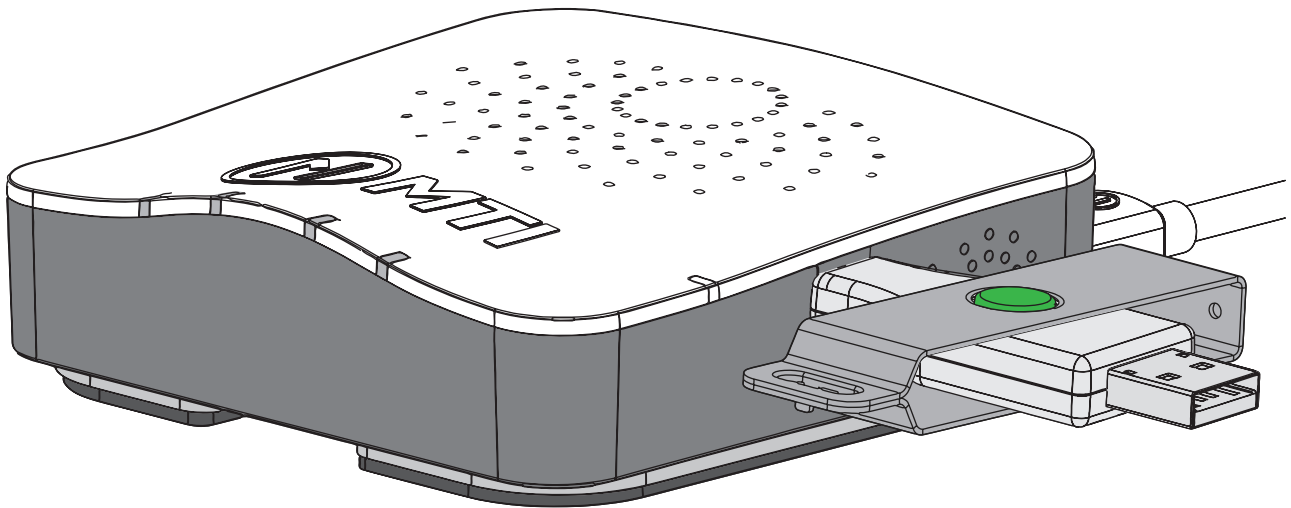

- 3 Remove IntelliKey from Alarm Module to arm the system. Lights will illuminate white indicating each port is armed. Ports will only illuminate white if a sensor is plugged into that port. Alarm module will automatically arm after 1 minute if devices are merchandised.

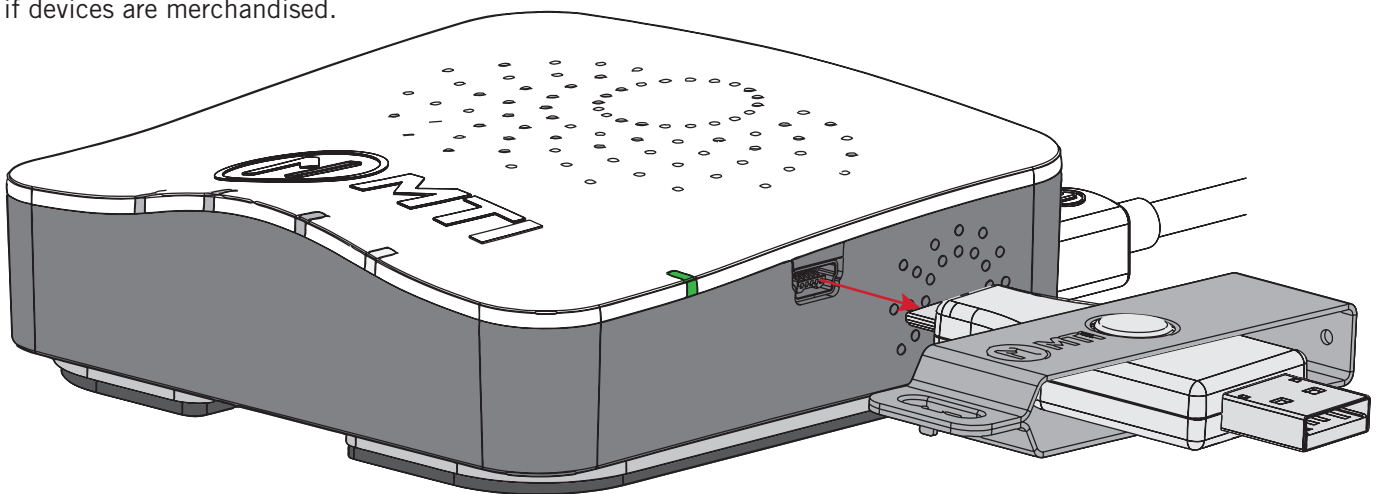

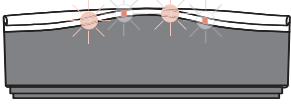
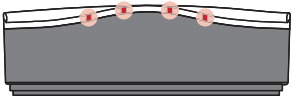
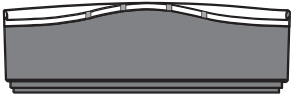
| Visual Reference | System Status | Condition | Solution |
|---|---|--|--|
|  | Alarm Module solid white No audible alarm | Power is on, Alarm Module is armed | Fully-functional, the device is secure and should be charging attached devices where appropriate |
|  | Alarm Module white single flash every 8 seconds No audible alarm | Power is on, Alarm Module is disarmed | Mount customer product and arm system |
|  | Alarm Module flashes red and white Steady alarm | Alarm Module is in a state of alarm due to theft, tampering or improperly mounted customer product | Insert IntelliKey to reset alarm Fix alarming condition (check mounted product) Remove IntelliKey |
|  | Alarm Module flashes red and white No audible alarm | Alarm Module has been alarming for more than 10 minutes | Insert IntelliKey to silence alarm Fix alarming condition (check mounted product) Remove IntelliKey |
|  | Alarm Module LED solid red No audible alarm | Over current from the device(s) or short circuit in Alarm Module | One device or combination of all devices are too power hungry for Freedom Core II™ system and cannot be merchandised as is Replace Alarm Module |
|  | LEDS off 5 double-beeps immediately after power is disconnected | System is in a state of battery back-up mode | Reconnect power |

In order to maximize consumer shopping experience during open hours, consider the following steps to extend battery life:

- **TURN OFF** or put all displayed devices/SKUs in **SLEEP** mode for the off hours for your store
- Lower the display brightness level (during open hours) on your devices by 15-20%

If you experience any condition not listed above, please contact Customer Service at 1-800-426-6844, Opt. 1

- 1** Insert the IntelliKey into the port on the side of the Alarm Module until the Intellikey's LED turns green to disarm the Alarm Module. Remove any sensors (page 7), then simply reverse the installation process (page 3/4) after replacing the VHB.

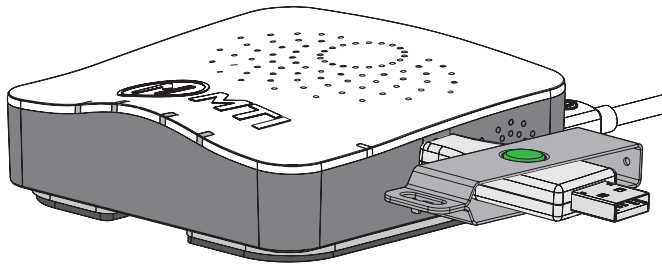

- 2** To remove a VHB position, Hold the Adhesive Pad Removal Tool with both hands and using a sawing motion, until the VHB is released from the base plate. Remove excess VHB by rolling it off the surfaces.

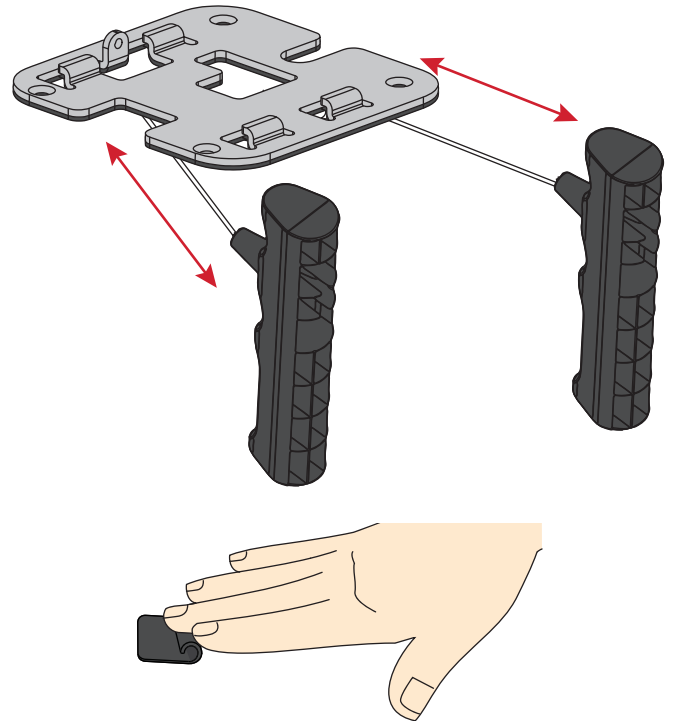

- 3** Clean the underside of the Mounting Bracket with an alcohol wipe and allow to dry.

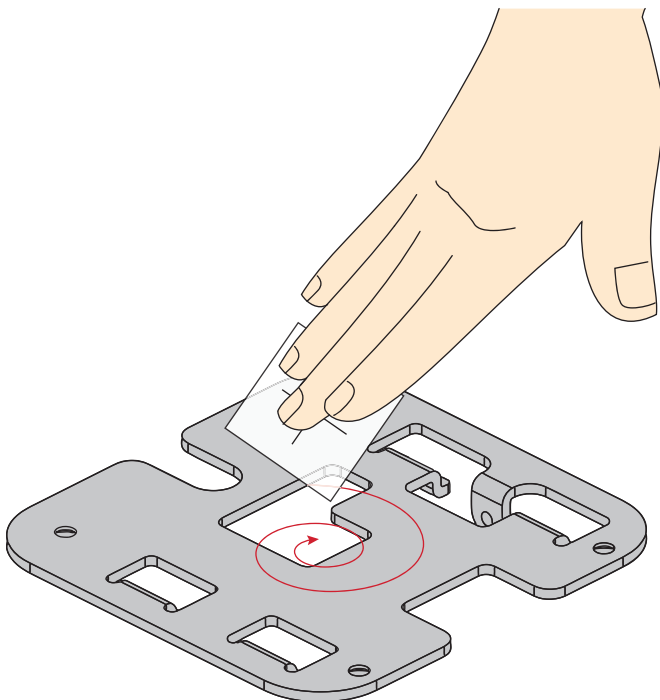

- 4** Peel a new VHB pad off of the sheet and place it on the underside of the bracket.

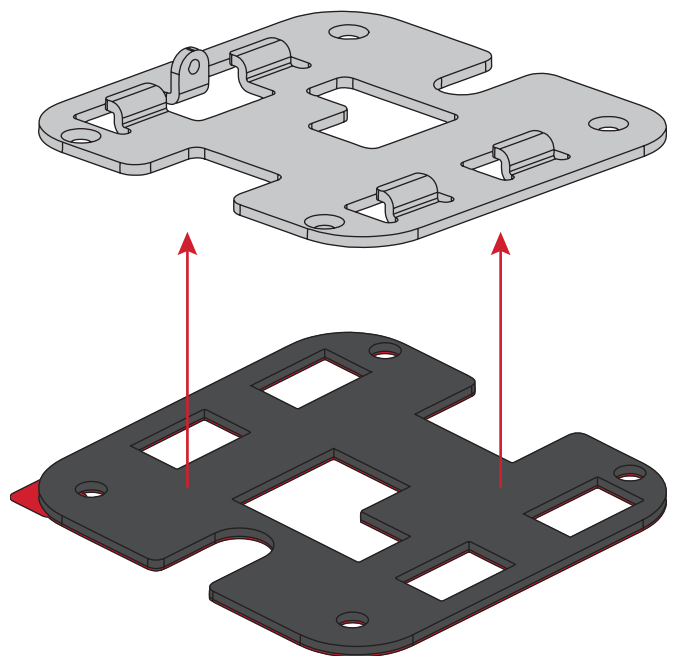

Seller warrants all Products manufactured by Seller to be free from defects in material and workmanship. Seller's warranty shall begin on the date of shipment to Customer. The length of the warranty is determined by the Product type as set forth below.

Base units, display puck assemblies (enclosure and ECB, excluding puck battery), alarm modules (enclosure and ECB), Piezo alarms, secondary sensors, electronic security sensors, quad cables, power/data link cables, IntelliKey Switch Module assemblies, Keyswitch assemblies, Keypad assemblies, puck adapters and custom design brackets/adapters for the Freedom™ Consumer Electronic Handheld (CEhh) Merchandising System ("Freedom™ System"), and NFC electronics boards in the Freedom™ System, all OnSite® switching modules and video/audio switching and distribution modules for the Audition Signal Management System ("Audition System"), multimedia players, format converters, resolution scalers and audio/video cables for the Audition System are warranted for a period of one (1) year.

CarbonTether™ assemblies, both powered and mechanical and SmartTether™ assemblies are warranted for a period of one (1) year.

AirTether™ assemblies are warranted for a period of six (6) months.

Seller provides no warranty hereunder for Power Supplies, and Customer must rely solely upon any warranty provided by the manufacturer of such Power Supplies. Certain manufacturer warranties are on file with Seller and may be made available upon Customer's request. Seller warrants all batteries to be free from defects in materials and factory workmanship, and warrants any battery that fails to perform as specified within six (6) months after date of shipment. This warranty shall not apply if buyer fails to notify MTI of such defect within ten (10) days after discovery, or if battery has been subjected to misuse, negligence or accident.

The following components of the Freedom™ System are considered consumable items and Seller provides no warranty for such items: USB interconnect cables, extension cables, SmartCables, FlexSensors, Membrane Sensors, anti-skid pads, anti-rotation brackets, VHB adhesive pads, X- and L-brackets, CC- and DC-brackets, cable clamps, zip ties, and installation, retrieval and removal tools. Unused SmartCables and Secondary Sensors that are demonstrated by Customer to have been faulty upon delivery to Customer will be replaced at Seller's expense; provided, however, Customer shall be responsible for any and all related shipping and handling costs.

All other Seller-manufactured Products, not specified above, are warranted for a period of one (1) year.

Seller's warranty expressed herein does not apply to the following:

- Cartons, cases, cabinets, displays, or any other unit attached to or otherwise connected to a Seller-manufactured Product.
- The labor and other costs associated with the removal and replacement of the warranted Product or any component thereof.
- Products used in applications beyond their normal intended use, application, or rated specifications.
- Products damaged by accident, abuse, improper voltage, faulty installations, mechanical failure, fire, flood, lightning, civil unrest, or any act of God.
- Warranty services rendered by any party other than Seller unless so authorized by Seller.
- Replacement parts and equipment that have been discontinued or are otherwise unavailable.
- Products from other manufacturers that are integrated by Seller into Customer's system(s) are not warranted by Seller and are subject only to that warranty, if any, provided by the manufacturer of such Product(s).

Subject to the limitations stated herein, and at Seller's sole discretion, Seller will replace or repair defective Products or components thereof at no charge to Customer so long as Customer's account with Seller is current and Customer has returned the Product(s) or component thereof pursuant to a properly issued Return Material Authorization.

Replacement of any Product or any component thereof by Seller under this warranty provision shall not extend, in any way, the length of the original applicable warranty period otherwise provided for herein.

Seller reserves the right to replace a defective Product or component thereof with a refurbished Product or component.

Seller's warranty herein is non-transferable and shall extend only to Customer.